



Premium Hydronic System
H Series HT

R-410A Refrigerant
Dual Stage
8-15 Ton

- [Design Features](#)
- [Controls](#)
- [Application Notes](#)
- [Physical Elements](#)
- [Dimensions](#)
- [Electrical](#)
- [Antifreeze Correction](#)
- [Performance](#)
- [Pressure Drop](#)
- [Wiring](#)
- [Accessories](#)
- [Engineering Specs](#)



GEOSMART
ENERGY



SPECIFICATION CATALOGUE

Table of Contents

Model Nomenclature	2
The Premium H	3-4
Inside the Premium H	5-6
Water Quality	7
Premium H Controls	8-9
Premium H Application Notes	10-12
Flow Rates	13
HT Typical Application Piping	13
AHRI Data	14
Dimensional Data	15
Physical Data	16
Electrical Data	16
Load and Source Pressure Drop	16
Antifreeze Correction	17
Reference Calculations	18
Legends and Notes	18
Performance Data	19-26
Wiring Schematics	27-29
Engineering Guide Specifications	30-31

Model Nomenclature

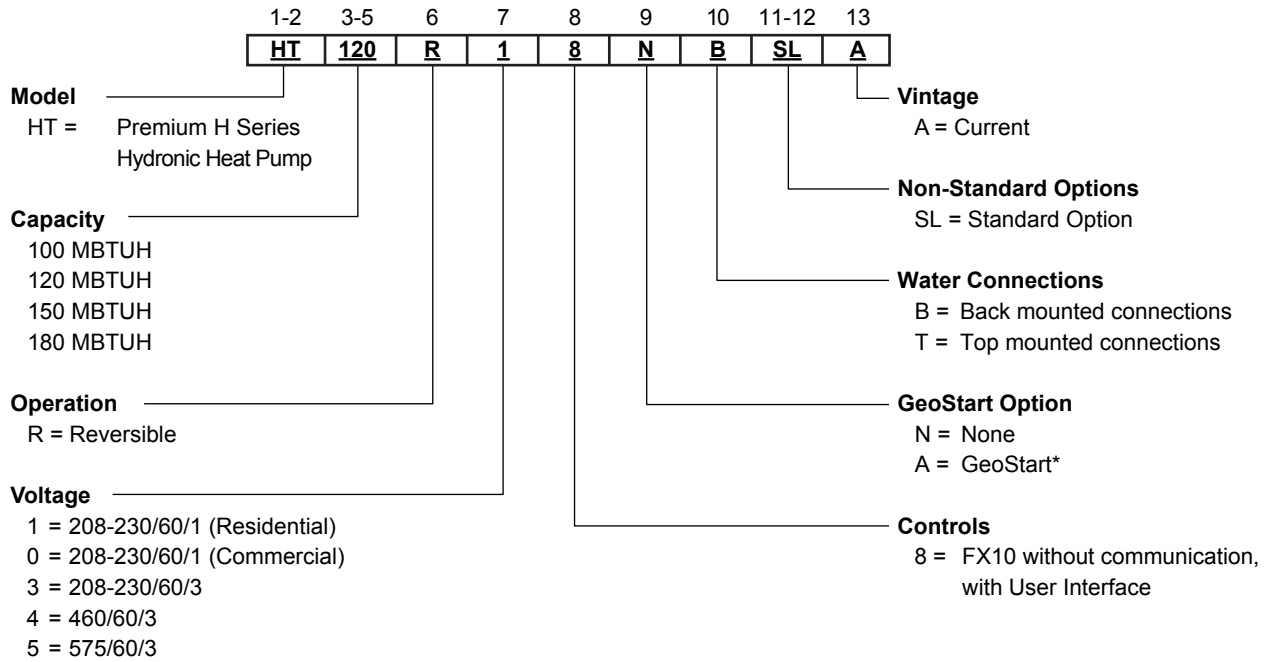

NOTE: *GeoStart available only on 208-230/60/1 units.

10/2/09



All Premium H product is Safety listed under UL1995 thru ETL and performance tested in accordance with standard AHRI/ISO 13256-2. AHRI does not currently certify water-to-water products under AHRI/ISO 13256-2.

The Premium H

HT Features

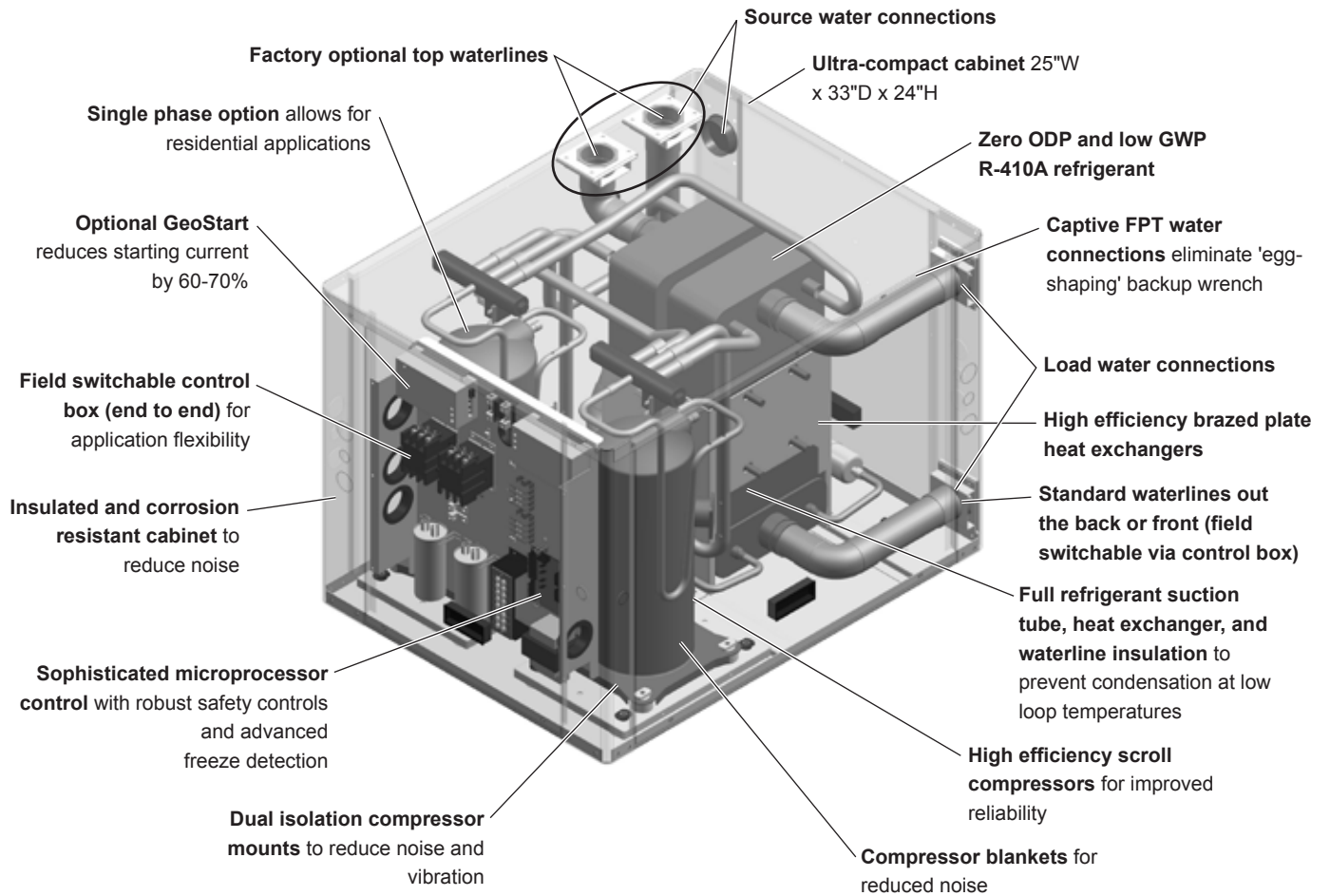

The Premium H

High Efficiency

The Premium H are the highest efficiency units available. Large oversized water to refrigerant heat exchangers and scroll compressors provide extremely efficient operation. This efficiency means the Premium H requires less loop than any product on the market. This can mean significant savings on commercial and residential projects.

Standard Features

- Single phase is available.
- Heavy gauge cabinet
- Quiet scroll compressors in all models
- Two-dimension refrigerant piping vibration loops to isolate the compressor.
- All interior cabinet surfaces are insulated with 1/2" [12.7mm] thick 1-1/2lb [681g] density, surface coated, acoustic type glass fiber insulation.
- Optional GeoStart to reduce starting current
- Field switchable control box
- Advanced FX10 control
- Ultra-compact cabinet
- Optional top or back mounted water lines

Super Quiet Option

- Multi-density laminate lined compressor blanket designed to completely surround the compressor on all six sides and suppress low frequency noise.



Flexible Control Options

The FX10 control provides unmatched capability in several areas including performance monitoring, zoning, humidity, energy management, and service diagnosis, and then communicates it all thru standard DDC protocols like N2, Lon and BACnet (MS/TP @ 19,200 Baud Rate). The most unique feature is integrating the FX10 into the Premium H as both the heat pump and DDC controller providing both a cost advantage and features not typically found on WLHP controls. This integration allows heat pump monitoring sensors, status and service diagnosis faults to be communicated thru the DDC direct to the building automation system (BAS), giving building supervisors detailed and accurate information on every piece of equipment without removing an access panel!

Easy Maintenance and Service Advantages

- Removable compressor access panels.
- Quick attach wiring harnesses are used throughout for fast servicing.
- High and low pressure refrigerant service ports.
- Optional user interface for diagnostics and commissioning of FX controls.

Factory Quality

- All refrigerant brazing is performed in a nitrogen purge environment.
- Computer controlled deep vacuum and refrigerant charging system.
- All joints are leak detected for maximum leak rate of less than 1/4 oz. per year.
- Computer bar code equipped assembly line insures all components are correct.
- All units are computer run-tested with water to verify both function and performance.

Inside the Premium H

Refrigerant

Premium H products all feature zero ozone depletion and low global warming potential R-410A refrigerant.

Cabinet

All units are constructed of corrosion resistant galvanized sheet metal with silver metallic powder coat paint rated for more than 1000 hours of salt spray. Large lift-out access panels provide access to the compressor section from four sides. Back or top water connection option is available.

Compressors

High efficiency R-410A scroll compressors are used on every model. Scrolls provide both the highest efficiency available and great reliability.

Electrical Box

Unit controls feature quick connect wiring harnesses for easy servicing. Separate knockouts for low voltage, and two for power on two sides allow easy access to the control box. A large 75VA transformer assures adequate control's power for accessories. Flexible Johnson Controls FX10 microprocessor control is included, featuring several innovations. See Premium H Controls section for more information.

Water Connections

Flush mount FPT water connection fittings allow one wrench leak-free connections and do not require a backup wrench. Factory installed thermistors are used on all water lines and can be viewed through the microprocessor interface tool.

Thermostatic Expansion Valve

All Premium H models utilize a balanced port bi-directional thermostatic expansion valve (TXV) for refrigerant metering. This allows precise refrigerant flow in a wide range of entering water variation (20 to 120°F [-7 to 49°C]) found in geothermal systems. The TXV is located in the compressor compartment for easy access.



Water-to-Refrigerant Heat Exchanger

Large oversized stainless steel interlaced copper-brazed plate water-to-refrigerant heat exchangers provide unparalleled efficiency. The heat exchangers have common water circuits with isolated refrigerant circuits so that in part load operation, the full mass of the heat exchanger is utilized. All heat exchangers are pressure rated to 450 psi water side and 650 psi refrigerant side. All heat exchangers, water lines, and suction lines are insulated to prevent condensation during low temperature inlet water operation.



Load and Source Piping Connections

The HT has two connection options available. Each kit is intended to connect one piping connection. Therefore, two kits will be required for each unit. The kits can be mixed for installer convenience, one on source and the other on load.

CKNDW1 - Strainer Connection Kit includes a 2" copper tee with integral P/T plug and a 2" "Y" strainer. Other components to complete the all copper piping can be sourced locally.

HHK162S - Strainer Hose Kit set includes 2" Hose kit includes a 2" stainless steel braided hose with integral P/T plug and 2" "Y" strainer.

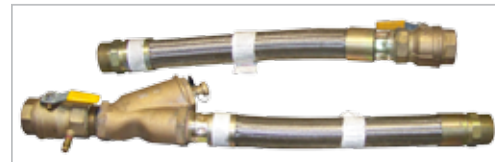

HHK162S



CKNDW1

Strainers

All units shall have a field-installed 2" Y-strainer with a self-aligning screen and 1" blow-off port to reduce debris that will enter the condenser/evaporator. Strainers should be made of a brass body with a 316 stainless steel 20-40 mesh screen.



WARNING: Warranty is void if strainers are not used on the entering side of the load and source.

Service Connections and Serviceability

Two Schrader service ports are provided for each circuit on every unit. The suction side and discharge side ports are for field charging and servicing access. All valves are 7/16" SAE connections.



Inside the Premium H cont.

4-Way Reversing Valve

Premium H units feature a reliable all-brass pilot operated refrigerant reversing valve. The reversing valve operation is limited to change of mode by the control to enhance reliability.



GeoStart™

The optional GeoStart single phase soft starter will reduce the normal start current (LRA) by 60-70%. This allows the heat pump to go off-grid. Using GeoStart also provides a substantial reduction in light flicker, reduces start-up noise, and improves the compressor's start behavior. GeoStart is available in a field retrofit kit or as a factory installed option for all Premium H and QT Series units.



Water Quality

General

HT systems may be successfully applied in a wide range of residential, commercial, and industrial applications. It is the responsibility of the system designer and installing contractor to ensure that acceptable water quality is present and that all applicable codes have been met in these installations.

Water Treatment

Do not use untreated or improperly treated water. Equipment damage may occur. The use of improperly treated or untreated water in this equipment may result in scaling, erosion, corrosion, algae or slime. The services of a qualified water treatment specialist should be engaged to determine what treatment, if any, is required. The product warranty specifically excludes liability for corrosion, erosion or deterioration of equipment.

The heat exchangers in the units are 316 stainless steel plates with copper brazing. The water piping in the heat exchanger is steel. There may be other materials in the building's piping system that the designer may need to take into consideration when deciding the parameters of the water quality.

If an antifreeze or water treatment solution is to be used, the designer should confirm it does not have a detrimental effect on the materials in the system.

Contaminated Water

In applications where the water quality cannot be held to prescribed limits, the use of a secondary or intermediate heat exchanger is recommended to separate the unit from the contaminated water.

The following table outlines the water quality guidelines for unit heat exchangers. If these conditions are exceeded, a secondary heat

exchanger is required. Failure to supply a secondary heat exchanger where needed will result in a warranty exclusion for primary heat exchanger corrosion or failure.

Strainers

These units must have properly sized strainers upstream of both brazed plate heat exchangers to protect them against particles in the fluid. Failure to install proper strainers and perform regular service can result in serious damage to the unit, and cause degraded performance, reduced operating life and failed compressors. Improper installation of the unit (which includes not having proper strainers to protect the heat exchangers) can also result in voiding the warranty.

Field supplied strainers with 20-40 mesh (530-1060 microns) are recommended, with 30 mesh (800 microns) being the optimum choice. The strainers selected should have a mesh open area of at least 6 square inches (39 square centimeters) for each unit being serviced by the strainer. Using strainers with a smaller amount of open area will result in the need for more frequent cleaning.

Strainers should be selected on the basis of acceptable pressure drop, and not on pipe diameter. The strainers selected should have a pressure drop at the nominal flow rate of the units low enough to be within the pumping capacity of the pump being used.



WARNING: Must have intermediate heat exchanger when used in pool applications.

Water Quality Guidelines

Material		Copper	90/10 Cupro-Nickel	316 Stainless Steel
pH	Acidity/Alkalinity	7 - 9	7 - 9	7 - 9
Scaling	Calcium and Magnesium Carbonate	(Total Hardness) less than 350 ppm	(Total Hardness) less than 350 ppm	(Total Hardness) less than 350 ppm
Corrosion	Hydrogen Sulfide	Less than .5 ppm (rotten egg smell appears at 0.5 PPM)	10 - 50 ppm	Less than 1 ppm
	Sulfates	Less than 125 ppm	Less than 125 ppm	Less than 200 ppm
	Chlorine	Less than .5 ppm	Less than .5 ppm	Less than .5 ppm
	Chlorides	Less than 20 ppm	Less than 125 ppm	Less than 300 ppm
	Carbon Dioxide	Less than 50 ppm	10 - 50 ppm	10- 50 ppm
	Ammonia	Less than 2 ppm	Less than 2 ppm	Less than 20 ppm
	Ammonia Chloride	Less than .5 ppm	Less than .5 ppm	Less than .5 ppm
	Ammonia Nitrate	Less than .5 ppm	Less than .5 ppm	Less than .5 ppm
	Ammonia Hydroxide	Less than .5 ppm	Less than .5 ppm	Less than .5 ppm
	Ammonia Sulfate	Less than .5 ppm	Less than .5 ppm	Less than .5 ppm
	Total Dissolved Solids (TDS)	Less than 1000 ppm	1000-1500 ppm	1000-1500 ppm
Iron Fouling (Biological Growth)	LSI Index	+0.5 to -.05	+0.5 to -.05	+0.5 to -.05
	Iron, Fe ²⁺ (Ferrous) Bacterial Iron Potential	< .2 ppm	< .2 ppm	< .2 ppm
	Iron Oxide	Less than 1 ppm. Above this level deposition will occur.	Less than 1 ppm. Above this level deposition will occur.	Less than 1 ppm. Above this level deposition will occur.
Erosion	Suspended Solids	Less than 10 ppm and filtered for max of 600 micron size	Less than 10 ppm and filtered for max of 600 micron size	Less than 10 ppm and filtered for max of 600 micron size
	Threshold Velocity (Fresh Water)	< 6 ft/sec	< 6 ft/sec	< 6 ft/sec

Grains = PPM divided by 17 • mg/l is equivalent to PPM

Premium H Controls

FX10 Control

The FX10 control provides unparalleled capability in several areas including performance monitoring, energy management, and service diagnosis, and then communicates it all thru standard DDC protocols like N2, Lon and BACnet (MS/TP @ 19,200 Baud Rate).

The most unique feature is integrating the FX10 into the Premium H as both the heat pump and DDC controller providing both a cost

advantage and providing features not typically found on WLHP controls. This integration allows heat pump monitoring sensors, status and service diagnosis faults to be communicated thru the DDC direct to the building automation system (BAS), giving building supervisors detailed and accurate information on every piece of equipment without removing an access panel!

Control	General Description	Application	Display/Interface	Protocol
<p>FX10</p> 	<p>The FX10 microprocessor control is self contained control featuring LP, LOC, HP, LWT, and condensate overflow fault modes can be displayed on BAS system. Optional handheld Medium User Interface (MUI) Control can be used for additional setup or servicing. Program customization is possible.</p>	<p>Cannot be integrated with centralized building automation systems. Software can be customized for specific projects.</p>	<p>Optional Medium User Interface (MUI) can be used as a field service tool.</p>	<p>Standalone</p>

Premium H Controls - FX10

FX10 Advanced Control Overview

- The Johnson Controls FX10 board is specifically designed for commercial heat pumps and provides control of the entire unit as well as input ports for Open N2, LonTalk, BACnet (MS/TP @ 19,200 Baud Rate) communication protocols as well as an input port for a user interface. The user interface can be used to aid in diagnostics and unit setup and is standard on all HT units. A 16-pin low voltage terminal board provides terminals for common field connections. The FX10 Control provides:
 - Operational sequencing
 - High and low-pressure switch monitoring
 - General lockout
 - Advanced Freeze Detection Temperature Sensing
 - Lockout mode control
 - Emergency shutdown mode
 - Random start and short cycle protection

Short Cycle Protection

Allows a minimum compressor “off” time of five minutes and a minimum “on” time of two minutes.

Random Start

A delay of 1 to 120 seconds is generated after each power-up to prevent simultaneous startup of all units within a building after the release from an unoccupied cycle or power loss.

Emergency Shutdown

A field-applied dry contact can be used to place the control into emergency shutdown mode. During this mode, all outputs on the board are disabled.

Freeze Detection Temperature Limit

Field selectable for 15°F or 33°F (-9° or -0.56°C)

Installation Options

- Standalone controlled by standard room thermostat
- Integrated into BAS by adding communication module

Accessory Outputs

Quantity 1. Cycled with the compressor. Field selectable for normally open (factory default) or normally closed through the building automation system or user interface.

User Interface

4 x 20 backlit LCD



Main FX 10 Board

Optional Plug-in Communication Modules - (compatible with standard BAS protocols)

- Open N2
- LonTalk
- BACnet (MS/TP @ 19,200 Baud Rate)

Display

One local display is standard on all HT units. Up to 2 displays, either 1 local and 1 remote, or 2 remote. (A 2-display configuration requires identical displays.) Local display can be up to 3 meters from the controller, power supply, and data communication. Remote display can be up to 300 meters from the controller. Remote display must be independently powered with data communication done via 3 pole shielded cable.

Control Timing & Fault Recognition Delays

Lead compressor “ON” delay	90 seconds
(not applicable for single compressor models)	
Minimum compressor “ON” time.....	2 minutes
(except for fault condition)	
Short cycle delay	5 minutes
Random start delay	0-120 seconds
High pressure fault	<1 second
Low pressure fault	30 seconds
Freeze detection fault.....	0-30 seconds
Low pressure fault bypass.....	2 minutes

NOTES: Refer to Submittal Data SD1981, Application Guide AGFX10, or BACnet Protocol Implementation. Conformance Statement for more information.

Premium H Application Notes

The Closed Loop Heat Pump Concept

The basic principle of a water source heat pump is the transfer of heat into water from the space during cooling, or the transfer of heat from water into the space during heating. Extremely high levels of energy efficiency are achieved as electricity is used only to move heat, not to produce it. Using a typical Premium H, one unit of electricity will move four to five units of heat.

When multiple water source heat pumps are combined on a common circulating loop, the ultimate in energy efficiency is created: Our geothermal units on cooling mode are adding heat to the loop which the units in heating mode can absorb, thus removing heat from the area where cooling is needed, recovering and redistributing that heat for possible utilization elsewhere in the system. In modern commercial structures, this characteristic of heat recovery from core area heat generated by lighting, office equipment, computers, solar radiation, people or other sources, is an important factor in the high efficiency and low operating costs of our closed source heat pump systems.

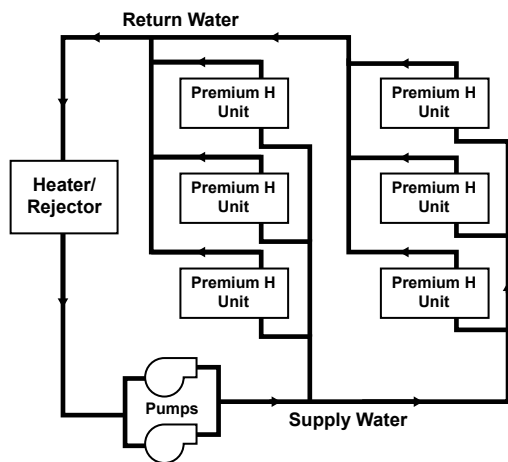

In the event that a building's net heating and cooling requirements create loop temperature extremes, Premium H units have the extended range capacity and versatility to maintain a comfortable environment for all building areas. Excess heat can be stored for later utilization or be added or removed in one of three ways; by ground-source heat exchanger loops: plate heat exchangers connected to other water sources, or conventional cooler/boiler configurations. Your representative has the expertise and computer software to assist in determining optimum system type for specific applications.

The Closed Loop Advantage

A properly applied water source heat pump system offers many advantages over other systems. First costs are low because units can be added to the loop on an "as needed basis"- perfect for speculative buildings. Installed costs are low since units are self-contained and can be located adjacent to the occupied space, requiring minimal ductwork. Maintenance can be done

on individual units without system shut-down. Conditions remain comfortable since each unit operates separately, allowing cooling in one area and heating in another. Tenant spaces can be finished and added as needed. Power billing to tenants is also convenient since each unit can be individually metered: each pays for what each uses. Nighttime and/or weekend uses of certain areas are possible without heating or cooling the entire facility. A decentralized system also means if one unit should fault, the rest of the system will continue to operate normally, as well as eliminating air cross-contamination problems and expensive high pressure duct systems requiring an inefficient electric resistance reheat mode.

Premium H Approach

There are a number of proven choices in the type of Premium H system which would be best for any given application. Most often considered are:

Closed Loop/Ground Source Vertical

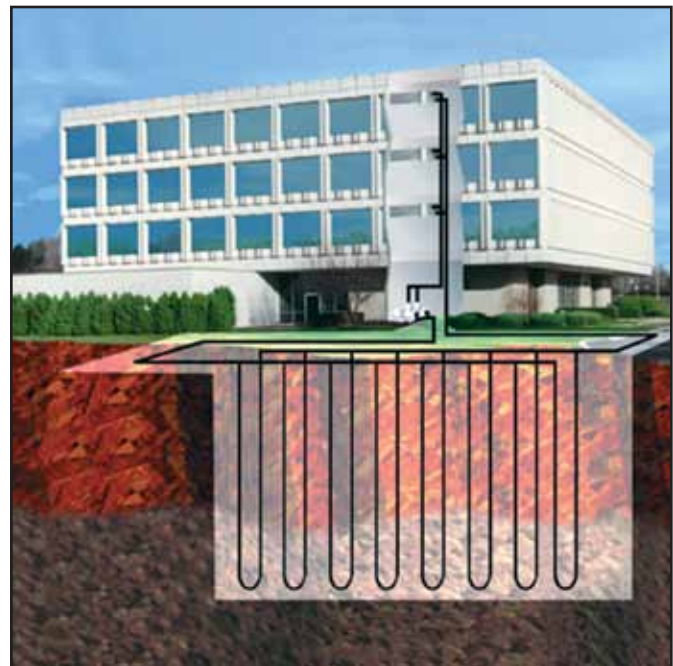

• **Closed Loop/Ground-Source Systems** utilize the stable temperatures of the earth to maintain proper water source temperatures (via vertical or horizontal closed loop heat exchangers) for Premium H extended range heat pump system. Sizes range from a single unit through many hundreds of units. When net cooling requirements cause closed loop water temperatures to rise, heat is dissipated into the cooler earth through buried high strength plastic pipe "heat exchangers." Conversely if net space heating demands cause loop heat absorption beyond that heat recovered from building core areas, the loop temperature will fall causing heat to be extracted from the earth. Due to the extended loop temperatures, AHRI/ISO 13256-1 Ground Loop Heat Pumps are required for this application.

Premium H Application Notes

Because auxiliary equipment such as a fossil fuel boiler and cooling tower are not required to maintain the loop temperature, operating and maintenance costs are very low. Ground-source systems are most applicable in residential and light commercial buildings where both heating and cooling are desired, and on larger envelope dominated structures where core heat recovery will not meet overall heating loads. Both vertical and horizontally installed closed-loops can be used. The land space required for the "heat exchangers" is 100-250 sq. ft./ton on vertical (drilled) installations and 750-1500 sq. ft./ton for horizontal (trenched) installations. Closed loop heat exchangers can be located under parking areas or even under the building itself.

On large multi-unit systems, sizing the closed loop heat exchanger to meet only the net heating loads and assisting in the summer with a closed circuit cooling tower may be the most cost effective choice.

Closed Loop/Ground Source Surface Water

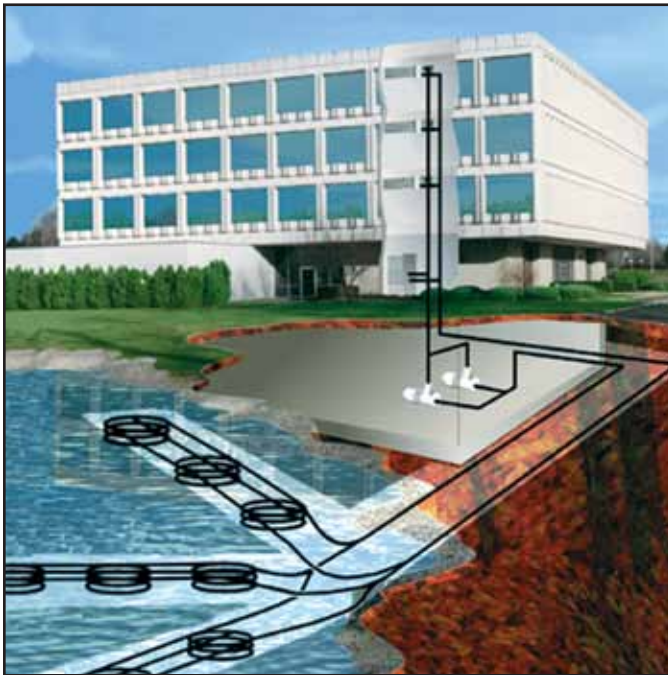

• **Closed Loop/Ground-Source Surface Water Systems** also utilize the stable temperatures of Surface Water to maintain proper water source temperatures for Premium H extended range heat pump systems. These systems have all of the advantages of horizontal and vertical closed loop systems. Due to the extended loop temperatures, AHRI/ISO 13256-1 Ground Water or Ground Loop Heat Pumps are required for this application.

In cooling dominated structures, the ground-source surface water systems can be very cost effective especially where local building codes require water retention ponds for short term storage of surface run-off. Sizing requirements for the surface water is a minimum of 500 sq. ft./ton of surface area at a minimum depth of 8 feet. The supplier should be contacted when designs for heating dominated structures are required.

Closed Loop/Ground Water Plate Heat Exchanger

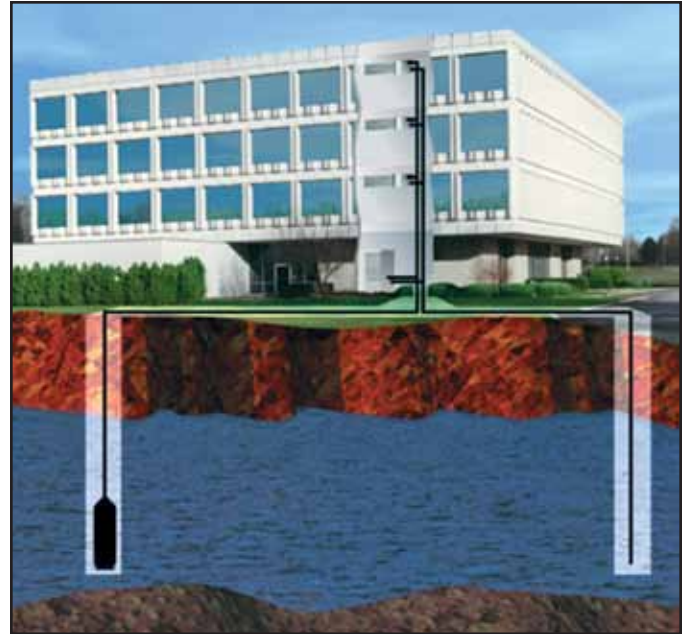

• **Closed Loop/Ground Water Plate Heat Exchanger Systems** utilize lake, ocean, well water or other water sources to maintain closed loop water temperatures in multi-unit Premium H systems. A plate frame heat exchanger isolates the units from any contaminating effects of the water source, and allows periodic cleaning of the heat exchanger during off peak hours.

Operation and benefits are similar to those for ground-source systems. Due to the extended loop temperatures, AHRI/ISO 13256-1 Ground Loop Heat Pumps are required for this application. Closed loop plate heat exchanger systems are applicable in commercial, marine, or industrial structures where the many benefits of a water source heat pump system are desired, regardless of whether the load is heating or cooling dominated.

Premium H Application Notes

Closed Loop Cooler - Boiler



• **Closed Loop /Cooler-Boiler Systems** utilize a closed heat recovering loop with multiple water source heat pumps in the more conventional manner. Typically a boiler is employed to maintain closed loop temperatures above 60°F and a cooling tower to maintain loop temperatures below 90°F. These systems are applicable in medium to large buildings regardless of whether the load is heating or cooling dominated. Due to the moderate loop temperatures, AHRI/ISO 13256-1 Water Loop Heat Pumps are required for this application.

Flow Rates

Load Flow Rate

The load flow on all water to water products including the HT Series should be 3 gpm per ton (typically the rated flow and the highest flow shown in the capacity charts). Refer to the table below. This flow rate is required especially when heating water to limit the effects of the higher condensing temperatures of water heating for radiant floor heating or domestic water use.

Source Flow Rate

The source flow can range between 2.25 and 3 gpm per ton for earth loops. For open loop well water systems the minimum flow should be 1.5 gpm per ton. In earth loop systems where entering water temperatures are expected to be above 95°F, 3 gpm per ton should be used. In well systems where the water temperature is below 50°F, 2 gpm per ton should be used to avoid nuisance freeze detection trips.

	Source Flow Rate				Load Flow Rate
	Minimum Open Loop	Open Loop < 50°F	Closed Loop Range (Min - Full Flow)		
HT100	15	20	23	30	30
HT120	18	24	27	36	36
HT150	21	28	32	42	42
HT180	24	32	36	48	48

HT Typical Application Piping

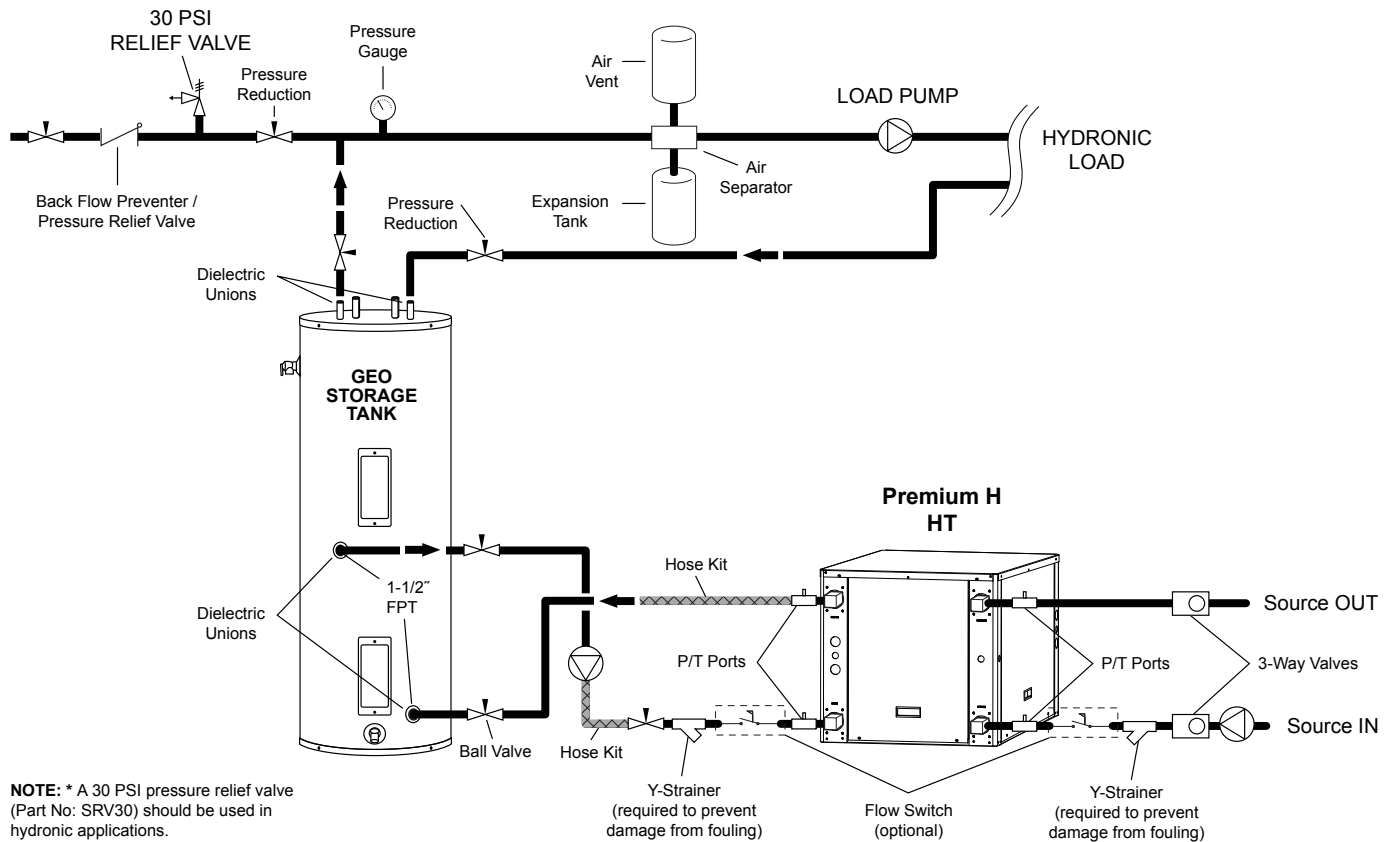

Performance Standard (AHRI/ISO/ASHRAE 13256-2)

The performance standard AHRI/ASHRAE/ISO 13256-2 became effective January 1, 2000. This new standard has three major categories: Water Loop, Ground Water, and Ground Loop.

Unit of Measure: The Cooling COP

The cooling efficiency is measured in EER (US version measured in Btuh per Watt. The Metric version is measured in a cooling COP (Watt per Watt) similar to the traditional COP measurement.

Pump Power Correction Calculation

Within each model, only one water flow rate is specified for all three groups and pumping Watts are calculated using the following formula. This additional power is added onto the existing power consumption.

- Pump power correction = (gpm x 0.0631) x (Press Drop x 2990) / 300

Where 'gpm' is waterflow in gpm and 'Press Drop' is the pressure drop through the unit heat exchanger at rated water flow in feet of head.

ISO Capacity and Efficiency Calculations

The following equations illustrate cooling calculations:

- ISO Cooling Capacity = Cooling Capacity (Btuh) x 3.412
- ISO EER Efficiency (W/W) = ISO Cooling Capacity (Btuh) x 3.412 / [Power Input (Watts) + Pump Power Correction (Watt)]

The following equations illustrate heating calculations:

- ISO Heating Capacity = Heating Capacity (Btuh) x 3.412
- ISO COP Efficiency (W/W) = ISO Heating Capacity (Btuh) x 3.412 / [Power Input (Watts) + Pump Power Correction (Watt)]

Test Conditions

	ISO/ARI 13256-2 WLHP	ISO/ARI 13256-2 GWHP	ISO/ARI 13256-2 GLHP
Cooling			
Liquid Entering Indoor Side - °F	53.6	53.6	53.6
<i>Standard Rating Test</i>			
Liquid Entering Heat Exchanger - °F	86	59	77
<i>Part-load Rating Test</i>			
Liquid Entering Heat Exchanger	86	59	68
Fluid Flow Rate	*	*	*
Heating			
Liquid Entering Indoor Side - °F	104	104	104
<i>Standard Rating Test</i>			
Liquid Entering Outdoor-side Heat Exchanger - °F	68	50	32
<i>Part-load Rating Test</i>			
Liquid Entering Outdoor-side Heat Exchanger	68	50	41
Fluid Flow Rate	*	*	*

NOTES: *Flow rate is specified by the manufacturer
 WLHP = Water Loop Heat Pump; GWHP = Ground Water Heat Pump;
 GLHP = Ground Loop Heat Pump

Conversions

Water Flow (lps) = GPM x 0.0631
 Press Drop (Pascals) = Press Drop (ft hd) x 2990

AHRI/ISO 13256-2 Performance Ratings

English (IP) Units

Model	Capacity Modulation	Flow Rate		Water Loop Heat Pump				Ground Water Heat Pump				Ground Loop Heat Pump			
				Cooling EWT 86°F ELT 53.6°F		Heating EWT 68°F ELT 104°F		Cooling EWT 59°F ELT 53.6°F		Heating EWT 50°F ELT 104°F		Cooling Full EST 77°F Part EST68°F ELT 53.6°F		Heating Full EST 32°F Part EST41°F ELT 104°F	
		gpm	cfm	Capacity Btuh	EER Btuh/W	Capacity Btuh	COP	Capacity Btuh	EER Btuh/W	Capacity Btuh	COP	Capacity Btuh	EER Btuh/W	Capacity Btuh	COP
100	Full	23	23	95,000	14.8	127,000	4.1	108,000	23.0	106,000	3.4	102,000	17.2	84,000	3.1
	Part	23	23	52,000	16.3	68,000	4.7	59,000	25.5	56,000	3.8	57,000	22.5	49,000	3.5
120	Full	28	28	105,000	14.2	145,000	4.0	125,000	22.0	120,000	3.3	116,000	16.5	95,000	3.0
	Part	28	28	60,000	15.8	78,000	4.5	67,000	24.0	64,000	3.8	65,000	21.5	56,000	3.4
150	Full	32	32	129,000	13.5	199,000	4.0	153,000	21.1	148,000	3.2	147,000	16.0	123,000	2.8
	Part	32	32	72,000	15.3	101,000	4.3	75,000	22.0	73,000	3.7	78,000	20.7	70,000	3.3
180	Full	36	36	150,000	13.3	221,000	3.9	175,000	19.8	173,000	3.1	165,000	15.8	139,000	2.7
	Part	36	36	78,000	15.0	113,000	4.2	89,000	20.9	87,000	3.7	86,000	18.4	82,000	3.5

NOTES: All ratings based upon 208V operation.
 Rated in accordance with but not certified by AHRI.
 AHRI does not currently certify water-to-water products under AHRI/ISO 13256-2.
 EnergyStar does not currently recognize water-to-water products.

Dimensional Data

HT100-180 - Top Waterline Configuration

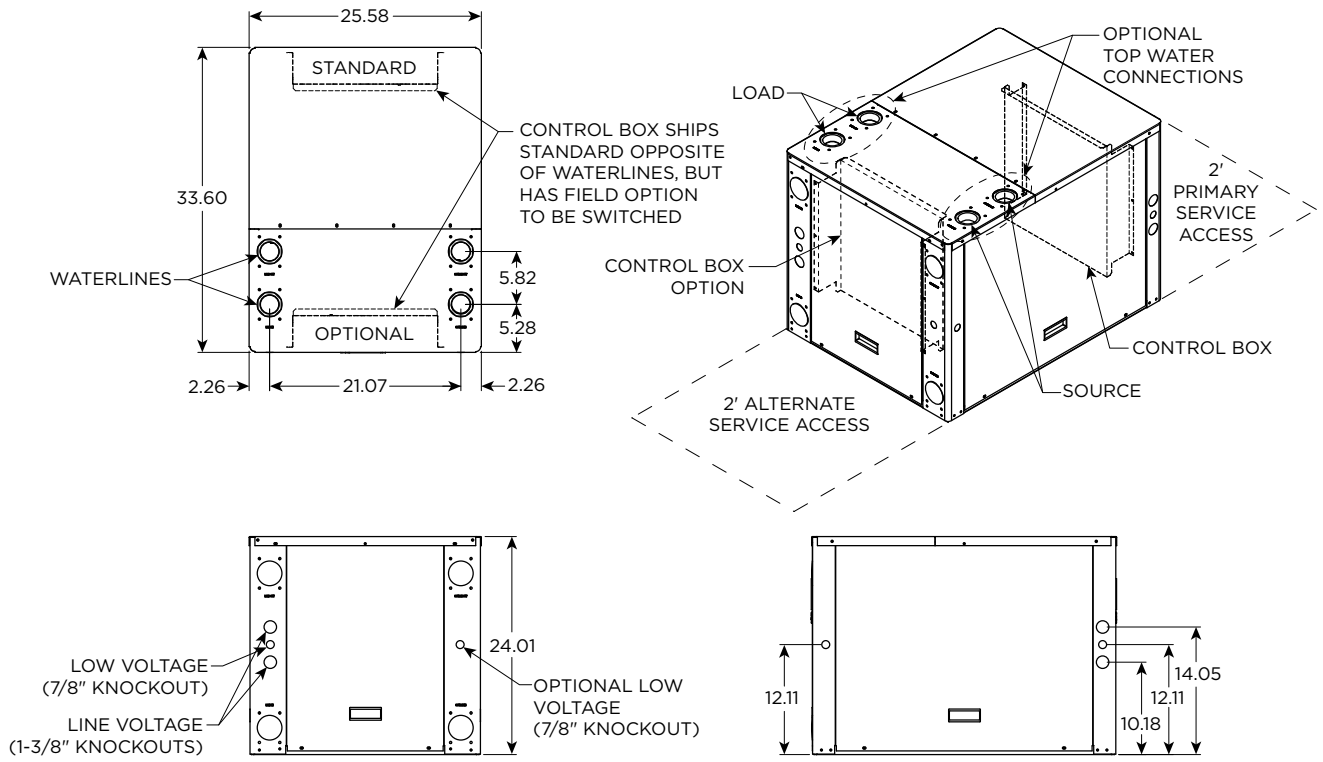

HT100-180 - Back Waterline Configuration

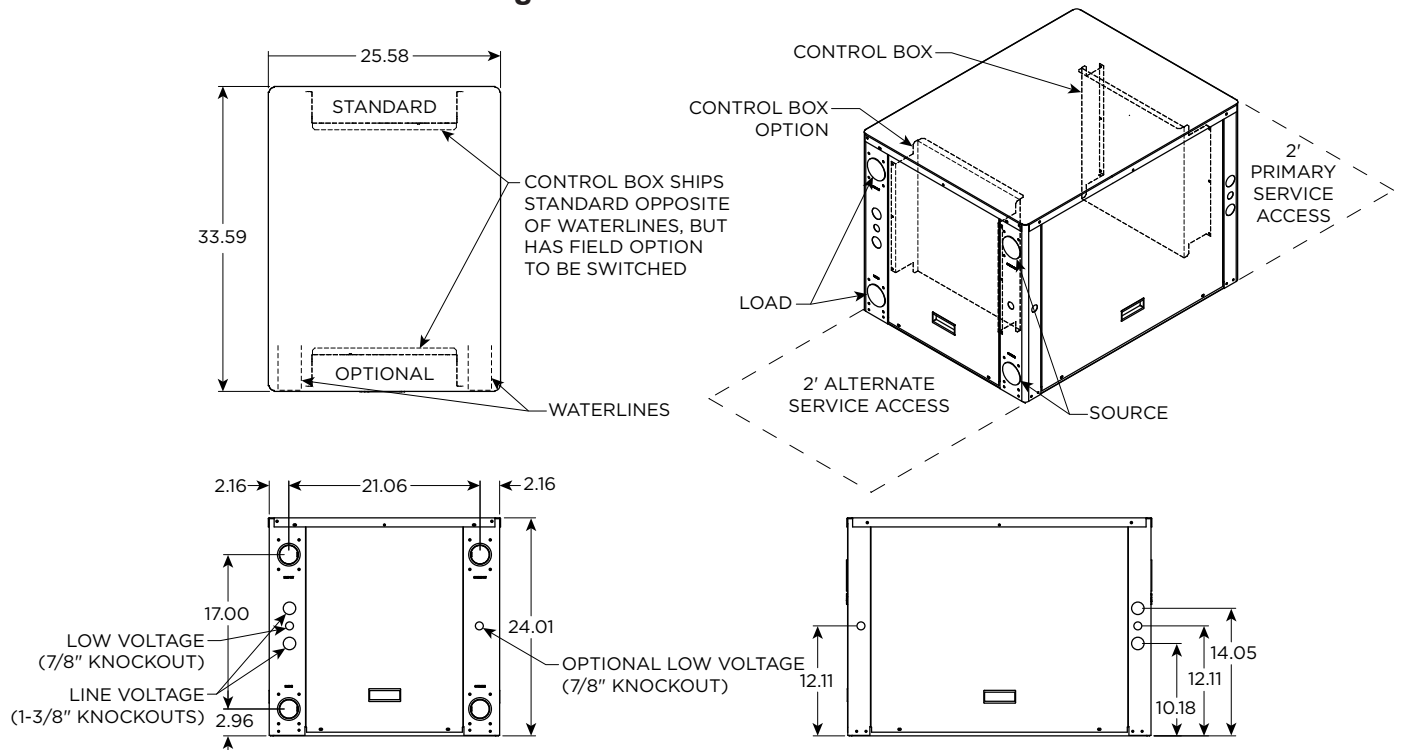

Physical Data

Model	HT			
	100	120	150	180
Compressor (2 each)	Scroll			
Factory Charge R410A, oz [kg]	62 [1.76]	62 [1.76]	62 [1.76]	62 [1.76]
Load Water Connection				
FPT - in	2	2	2	2
Source Water Connection				
FPT - in	2	2	2	2
Weight - Operating, lb [kg]	390 [177]	400 [181]	400 [181]	420 [190]
Weight - Packaged, lb [kg]	385 [175]	395 [179]	395 [179]	415 [188]

3/9/09

Electrical Data

Model	Supply Circuit	Rated Voltage	Voltage Min/Max	Compressor*				Load Pump FLA	Source Pump FLA	Total Unit FLA	Min Circ Amp	Max Fuse/HACR
				MCC	RLA	LRA	LRA**					
100	L1/L2	208-230/60/1	187/253	41.2	26.4	134.0	47.0	-	-	26.4	33.0	50
	L3/L4	208-230/60/1	187/253	41.2	26.4	134.0	47.0	4.2	4.2	34.8	41.4	60
	Single	208-230/60/3	187/253	24.9	16.0	110.0	-	-	-	32.0	36.0	50
	Single	460/60/3	414/506	12.1	7.8	52.0	-	-	-	15.6	17.6	25
	Single	575/60/3	517/633	8.9	5.7	38.9	-	-	-	11.4	12.8	15
120	L1/L2	208-230/60/1	187/253	47.0	30.1	145.0	51.0	-	-	30.1	37.6	60
	L3/L4	208-230/60/1	187/253	47.0	30.1	145.0	51.0	4.2	4.2	38.5	46.0	70
	Single	208-230/60/3	187/253	28.0	17.3	120.0	-	-	-	34.6	38.9	50
	Single	460/60/3	414/506	15.0	9.6	70.0	-	-	-	19.2	21.6	30
	Single	575/60/3	517/633	12.5	8.0	53.0	-	-	-	16.0	18.0	25
150	L1/L2	208-230/60/1	187/253	42.0	26.9	145.0	51.0	-	-	26.9	33.6	60
	L3/L4	208-230/60/1	187/253	42.0	26.9	145.0	51.0	4.2	4.2	35.3	42.0	60
	Single	208-230/60/3	187/253	35.0	22.4	190.0	-	-	-	44.8	50.4	70
	Single	460/60/3	414/506	19.0	12.2	87.0	-	-	-	24.4	27.5	30
	Single	575/60/3	517/633	15.0	9.6	62.0	-	-	-	19.2	21.6	30
180	L1/L2	208-230/60/1	187/253	50.0	32.1	185.0	65.0	-	-	32.1	40.1	70
	L3/L4	208-230/60/1	187/253	50.0	32.1	185.0	65.0	4.2	4.2	40.5	48.5	80
	Single	208-230/60/3	187/253	39.0	26.0	190.0	-	-	-	52.0	58.5	80
	Single	460/60/3	414/506	19.0	13.0	100.0	-	-	-	26.0	29.3	40
	Single	575/60/3	517/633	14.5	9.3	72.0	-	-	-	18.6	20.9	30

7/22/09

HACR circuit breaker in USA only

* Ratings per each compressor - unit supplied with two

** With optional IntelliStart (single phase only)

Load and Source Pressure Drop

Model	GPM	Pressure Drop (psi)				
		30°F	50°F	70°F	90°F	110°F
100	15	1.0	0.8	0.5	0.3	0.1
	23	2.5	2.2	2.0	1.7	1.3
	30	3.8	3.6	3.3	3.1	2.4
	34	4.5	4.3	4.0	3.8	3.0
120	18	1.6	1.3	1.1	0.8	0.6
	28	3.4	3.2	2.9	2.7	2.1
	36	4.9	4.7	4.4	4.2	3.3
	40	5.6	5.4	5.1	4.9	3.9
150	21	2.1	1.9	1.6	1.4	1.0
	32	4.2	3.9	3.7	3.4	2.7
	42	6.0	5.8	5.5	5.3	4.2
	50	7.5	7.3	7.0	6.8	5.5
180	24	2.7	2.4	2.2	1.9	1.5
	36	4.9	4.7	4.4	4.2	3.3
	48	7.1	6.9	6.6	6.4	5.1
	60	9.3	9.1	8.8	8.6	7.0

3/9/09

Antifreeze Correction

Catalog performance can be corrected for antifreeze use. Please use the following table and note the example given.

Antifreeze Type	Antifreeze % by wt	Heating		Cooling		Pressure Drop
		Load	Source	Load	Source	
EWT - °F [°C]		80 [26.7]	30 [-1.1]	50 [10.0]	90 [32.2]	30 [-1.1]
Water	0	1.000	1.000	1.000	1.000	1.000
Ethylene Glycol	10	0.990	0.973	0.976	0.991	1.075
	20	0.978	0.943	0.947	0.979	1.163
	30	0.964	0.917	0.921	0.965	1.225
	40	0.953	0.890	0.897	0.955	1.324
	50	0.942	0.865	0.872	0.943	1.419
Propylene Glycol	10	0.981	0.958	0.959	0.981	1.130
	20	0.967	0.913	0.921	0.969	1.270
	30	0.946	0.854	0.869	0.950	1.433
	40	0.932	0.813	0.834	0.937	1.614
	50	0.915	0.770	0.796	0.922	1.816
Ethanol	10	0.986	0.927	0.945	0.991	1.242
	20	0.967	0.887	0.906	0.972	1.343
	30	0.944	0.856	0.869	0.947	1.383
	40	0.926	0.815	0.830	0.930	1.523
	50	0.907	0.779	0.795	0.911	1.639
Methanol	10	0.985	0.957	0.962	0.986	1.127
	20	0.969	0.924	0.929	0.970	1.197
	30	0.950	0.895	0.897	0.951	1.235
	40	0.935	0.863	0.866	0.936	1.323
	50	0.919	0.833	0.836	0.920	1.399



WARNING: Gray area represents antifreeze concentrations greater than 35% by weight and should be avoided due to the extreme performance penalty they represent.

Antifreeze Correction Example

Antifreeze solution is propylene glycol 20% by weight for the source and methanol 10% for the load. Determine the corrected heating at 30°F source and 80°F load as well as pressure drop at 30°F for an Premium H HT120. Also, determine the corrected cooling at 90°F source and 50°F load.

The corrected heating capacity at 30°F/80°F would be:

$$98,500 \text{ MBTUH} \times 0.913 \times 0.985 = 88,582 \text{ MBTUH}$$

The corrected cooling capacity at 90°F/50°F would be:

$$113,200 \times 0.969 \times 0.962 = 105,523 \text{ MBTUH}$$

The corrected pressure drop at 30°F and 36 GPM would be:

$$4.9 \text{ psi} \times 1.270 = 6.22 \text{ psi}$$

Reference Calculations

Heating Calculations:	Cooling Calculations:
$LWT = EWT - \frac{HE}{GPM \times 500^*}$	$LWT = EWT + \frac{HR}{GPM \times 500^*}$

NOTE: * When using water. Use 485 for 15% methanol/water or Environol solution.

Legends and Notes

Abbreviations and Definitions

ELT = entering load fluid temperature to heat pump	PSI = pressure drop in pounds per square inch
LLT = leaving load fluid temperature from heat pump	FT HD = pressure drop in feet of head
LGPM = load flow in gallons per minute	KW = kilowatt
LWPD = load heat exchanger water pressure drop	HR = heat rejected in MBTUH
EST = entering source fluid temperature to heat pump	TC = total cooling capacity in MBTUH
LST = leaving source fluid temperature from heat pump	COP = coefficient of performance (HC/KW x 3.413)
SGPM = source flow in gallons per minute	HC = heating capacity in MBTUH
SWPD = source heat exchanger water pressure drop	HE = heat of extraction in MBTUH
EER = cooling energy efficiency (TC/KW)	

Notes to Capacity Data Tables

The following notes apply to all performance data tables:

- Three flow rates are shown for each unit. The lowest flow rate shown is used for geothermal open loop/well water systems with a minimum of 50°F EST. The middle flow rate shown is the minimum geothermal closed loop flow rate. The highest flow rate shown is optimum for geothermal closed loop systems and the suggested flow rate for boiler/tower applications.
- Entering water temperatures below 40°F assumes 15% antifreeze solution.
- Interpolation between ELT, EST, and GPM data is permissible.
- Operation in the gray areas is not recommended.

HT100 - Performance Data

Cooling Capacity

Source		Load Flow - 15 GPM							Load Flow - 23 GPM							Load Flow - 30 GPM						
EST °F	Flow GPM	ELT °F	LLT °F	TC MBTUH	Power kW	HR MBTUH	EER	LST °F	LLT °F	TC MBTUH	Power kW	HR MBTUH	EER	LST °F	LLT °F	TC MBTUH	Power kW	HR MBTUH	EER	LST °F		
30	15	50	35.6	108.0	3.80	121.0	28.4	44.5	41.3	111.7	3.91	125.1	28.6	45.0	43.1	115.0	4.00	128.6	28.8	47.2		
		70	54.3	117.9	3.90	131.2	30.2	45.7	60.5	121.7	3.99	135.3	30.5	46.2	62.5	125.0	4.07	138.9	30.7	48.5		
		90	73.0	127.9	4.00	141.5	32.0	47.0	79.7	131.7	4.07	145.6	32.3	47.5	81.9	135.0	4.13	149.1	32.7	49.9		
		110	91.6	137.8	4.10	151.8	33.6	48.2	98.9	141.6	4.15	155.8	34.1	48.7	101.3	145.0	4.20	159.3	34.5	51.2		
	23	50	35.3	110.1	3.69	122.7	29.8	39.6	41.1	113.8	3.80	126.7	29.9	39.9	43.0	116.9	3.89	130.2	30.0	41.3		
		70	54.0	120.3	3.76	133.1	32.0	40.4	60.3	124.1	3.86	137.3	32.2	40.7	62.3	127.5	3.94	141.0	32.3	42.3		
		90	72.6	130.4	3.83	143.5	34.1	41.2	79.5	134.5	3.92	147.9	34.4	41.6	81.7	138.1	3.99	151.7	34.6	43.2		
		110	91.3	140.6	3.90	153.9	36.1	42.0	98.7	144.9	3.97	158.5	36.5	42.4	101.1	148.7	4.04	162.5	36.8	44.1		
	30	50	35.1	112.0	3.60	124.3	31.1	37.5	41.0	115.5	3.71	128.2	31.2	37.7	42.9	118.6	3.80	131.6	31.2	38.8		
		70	53.7	122.3	3.64	134.8	33.6	38.1	60.1	126.3	3.74	139.1	33.7	38.3	62.2	129.7	3.83	142.8	33.8	39.5		
		90	72.3	132.7	3.68	145.2	36.1	38.7	79.3	137.0	3.78	149.9	36.3	39.0	81.5	140.9	3.87	154.1	36.4	40.3		
		110	90.9	143.0	3.72	155.7	38.4	39.3	98.4	147.8	3.82	160.8	38.7	39.6	100.9	152.0	3.90	165.3	39.0	41.0		
50	15	50	36.6	100.3	5.23	118.1	19.2	64.2	41.9	103.7	5.33	121.9	19.5	64.6	43.6	106.7	5.41	125.2	19.7	66.7		
		70	55.1	111.5	5.37	129.8	20.8	65.6	61.0	115.0	5.45	133.6	21.1	66.0	62.9	118.1	5.52	137.0	21.4	68.3		
		90	73.6	122.7	5.51	141.4	22.3	67.0	80.1	126.3	5.57	145.3	22.7	67.4	82.2	129.6	5.63	148.8	23.0	69.8		
		110	92.2	133.9	5.65	153.1	23.7	68.4	99.2	137.7	5.69	157.1	24.2	68.9	101.5	141.0	5.73	160.6	24.6	71.4		
	23	50	36.4	102.1	5.09	119.4	20.0	59.3	41.7	105.4	5.18	123.1	20.3	59.6	43.5	108.4	5.26	126.3	20.6	61.0		
		70	54.9	113.5	5.19	131.2	21.9	60.3	60.8	117.2	5.27	135.1	22.2	60.6	62.8	120.4	5.34	138.6	22.6	62.0		
		90	73.3	124.9	5.28	142.9	23.6	61.2	79.9	128.9	5.35	147.1	24.1	61.5	82.1	132.3	5.41	150.8	24.5	63.1		
		110	91.8	136.3	5.38	154.7	25.3	62.1	99.0	140.6	5.44	159.1	25.9	62.5	101.3	144.3	5.49	163.1	26.3	64.2		
	30	50	36.2	103.6	4.98	120.6	20.8	57.2	41.6	106.9	5.06	124.2	21.2	57.5	43.4	109.9	5.13	127.3	21.4	58.5		
		70	54.6	115.3	5.03	132.4	22.9	57.9	60.7	119.0	5.11	136.4	23.3	58.2	62.7	122.3	5.18	140.0	23.6	59.3		
		90	73.1	126.9	5.09	144.2	25.0	58.7	79.7	131.1	5.16	148.7	25.4	58.9	81.9	134.8	5.23	152.6	25.8	60.2		
		110	91.5	138.5	5.14	156.0	26.9	59.4	98.8	143.2	5.21	161.0	27.5	59.7	101.2	147.3	5.28	165.2	27.9	61.0		
70	15	50	37.7	92.5	6.65	115.2	13.9	83.8	42.5	95.6	6.74	118.7	14.2	84.2	44.1	98.4	6.83	121.7	14.4	86.2		
		70	56.0	105.0	6.83	128.3	15.4	85.4	61.5	108.3	6.91	131.9	15.7	85.8	63.3	111.3	6.97	135.1	16.0	88.0		
		90	74.3	117.4	7.02	141.4	16.7	87.0	80.5	121.0	7.07	145.1	17.1	87.4	82.6	124.1	7.12	148.4	17.4	89.8		
		110																				
	23	50	37.5	94.0	6.49	116.1	14.5	79.1	42.4	97.1	6.56	119.5	14.8	79.4	44.0	99.8	6.63	122.4	15.1	80.6		
		70	55.8	106.7	6.61	129.2	16.1	80.1	61.4	110.2	6.67	132.9	16.5	80.4	63.2	113.2	6.73	136.2	16.8	81.8		
		90	74.1	119.4	6.74	142.4	17.7	81.1	80.4	123.2	6.79	146.4	18.2	81.5	82.4	126.6	6.83	149.9	18.5	83.0		
		110																				
	30	50	37.3	95.3	6.35	116.9	15.0	77.0	42.3	98.4	6.40	120.2	15.4	77.2	43.9	101.1	6.45	123.1	15.7	78.2		
		70	55.6	108.2	6.42	130.1	16.8	77.8	61.3	111.8	6.47	133.8	17.3	78.0	63.1	114.9	6.52	137.1	17.6	79.1		
		90	73.9	121.1	6.49	143.2	18.7	78.6	80.2	125.1	6.54	147.5	19.1	78.8	82.3	128.7	6.58	151.2	19.5	80.1		
		110																				
90	15	50	38.7	84.8	8.08	112.3	10.5	103.5	43.1	87.6	8.16	115.5	10.7	103.9	44.6	90.1	8.24	118.2	10.9	105.8		
		70	56.9	98.5	8.30	126.8	11.9	105.2	62.0	101.6	8.37	130.2	12.1	105.6	63.7	104.4	8.42	133.1	12.4	107.8		
		90	75.0	112.2	8.53	141.3	13.2	107.0	80.9	115.7	8.57	144.9	13.5	107.4	82.9	118.7	8.61	148.1	13.8	109.7		
		110																				
	23	50	38.5	85.9	7.89	112.8	10.9	98.8	43.1	88.8	7.94	115.9	11.2	99.1	44.5	91.3	7.99	118.6	11.4	100.3		
		70	56.7	99.9	8.04	127.3	12.4	100.0	61.9	103.2	8.08	130.7	12.8	100.2	63.6	106.0	8.12	133.8	13.1	101.6		
		90	74.8	113.9	8.19	141.8	13.9	101.1	80.8	117.6	8.22	145.6	14.3	101.4	82.8	120.8	8.25	149.0	14.6	103.0		
		110																				
	30	50	38.4	86.9	7.73	113.2	11.2	96.8	43.0	89.8	7.75	116.2	11.6	97.0	44.5	92.4	7.78	118.9	11.9	97.9		
		70	56.5	101.1	7.81	127.7	12.9	97.7	61.8	104.5	7.84	131.2	13.3	97.9	63.6	107.5	7.86	134.3	13.7	99.0		
		90	74.6	115.3	7.90	142.2	14.6	98.5	80.7	119.2	7.92	146.2	15.1	98.8	82.6	122.6	7.94	149.7	15.4	100.0		
		110																				
110	15	50	39.7	77.0	9.50	109.4	8.1	123.1	43.8	79.6	9.58	112.2	8.3	123.5	45.1	81.8	9.65	114.7	8.5	125.3		
		70	57.7	92.0	9.77	125.3	9.4	125.0	62.6	95.0	9.83	128.5	9.7	125.4	64.1	97.5	9.88	131.2	9.9	127.5		
		90	75.7	107.0	10.03	141.2	10.7	126.9	81.4	110.3	10.07	144.7	11.0	127.4	83.2	113.3	10.10	147.7	11.2	129.7		
		110																				
	23	50	39.6	77.8	9.29	109.5	8.4	118.6	43.7	80.4	9.32	112.3	8.6	118.8	45.0	82.8	9.36	114.7	8.8	120.0		
		70	57.6	93.1	9.46	125.4	9.8	119.8	62.5	96.2	9.49	128.6	10.1	120.1	64.1	98.9	9.52	131.4	10.4	121.4		
		90	75.6	108.3	9.64	141.2	11.2	121.1	81.2	111.9	9.66	144.9	11.6	121.3	83.1	115.0	9.67	148.0	11.9	122.9		
		110																				
	30	50	39.5	78.5	9.10	109.5	8.6	116.6	43.6	81.2	9.10	112.3	8.9	116.7	45.0	83.6	9.10	114.6	9.2	117.6		
		70	57.5	94.0	9.20	125.4	10.2	117.5	62.4	97.2	9.20	128.6	10.6	117.7	64.0	100.1	9.20	131.5	10.9	118.8		
		90	75.4	109.5	9.30	141.2	11.8	118.5	81.1	113.3	9.30	145.0	12.2	118.7	83.0	116.5	9.30	148.3	12.5	119.9		
		110																				

HT100 - Performance Data

Heating Capacity

Source		Load Flow - 15 GPM							Load Flow - 23 GPM							Load Flow - 30 GPM						
EWT °F	Flow GPM	ELT °F	LLT °F	HC MBTUH	Power kW	HE MBTUH	COP	LST °F	LLT °F	HC MBTUH	Power kW	HE MBTUH	COP	LST °F	LLT °F	HC MBTUH	Power kW	HE MBTUH	COP	LST °F		
20	30	60	71.1	83.0	5.00	65.9	4.9	11.2	67.4	85.6	4.89	68.9	5.1	14.0	65.9	87.8	4.80	71.4	5.4	15.2		
		80	90.8	80.9	6.67	58.2	3.6	12.2	87.2	83.2	6.49	61.1	3.8	14.7	85.7	85.2	6.33	63.6	3.9	15.8		
		100	110.5	78.9	8.33	50.4	2.8	13.3	107.0	80.9	8.08	53.3	2.9	15.4	105.5	82.6	7.87	55.8	3.1	16.3		
		120	130.2	76.8	10.00	42.7	2.3	14.3	126.8	78.5	9.68	45.5	2.4	16.0	125.3	80.0	9.40	47.9	2.5	16.8		
30	23	60	72.2	91.3	5.01	74.2	5.3	20.1	68.2	94.5	4.85	78.0	5.7	23.2	66.5	97.3	4.71	81.2	6.1	24.6		
		80	91.9	89.2	6.64	66.6	3.9	21.1	88.0	92.1	6.46	70.1	4.2	23.9	86.3	94.7	6.31	73.2	4.4	25.1		
		100	111.6	87.2	8.28	58.9	3.1	22.1	107.8	89.8	8.08	62.2	3.3	24.6	106.1	92.1	7.91	65.1	3.4	25.7		
	30	120	131.3	85.1	9.91	51.3	2.5	23.2	127.6	87.4	9.70	54.3	2.6	25.3	126.0	89.5	9.51	57.0	2.8	26.2		
		60	72.3	92.0	5.10	74.6	5.3	20.1	68.4	96.3	4.94	79.4	5.7	23.1	66.7	100.0	4.80	83.6	6.1	24.4		
		80	92.0	89.9	6.77	66.8	3.9	21.1	88.2	93.9	6.59	71.4	4.2	23.8	86.5	97.4	6.43	75.4	4.4	25.0		
		100	111.7	87.9	8.43	59.1	3.1	22.1	108.0	91.6	8.24	63.5	3.3	24.5	106.3	94.8	8.07	67.3	3.4	25.5		
		120	131.4	85.8	10.10	51.3	2.5	23.2	127.8	89.2	9.89	55.5	2.6	25.2	126.1	92.2	9.70	59.1	2.8	26.1		
50	15	60	73.6	102.2	5.00	85.1	6.0	38.7	69.2	105.4	4.84	88.9	6.4	42.3	67.2	108.3	4.70	92.3	6.8	43.8		
		80	93.3	100.1	6.62	77.5	4.4	39.7	89.0	103.1	6.44	81.1	4.7	42.9	87.0	105.7	6.29	84.2	4.9	44.4		
		100	113.1	98.1	8.20	69.3	3.6	40.7	108.8	100.7	8.23	73.1	3.8	43.6	106.9	103.1	7.88	76.2	3.8	44.9		
		120	132.8	96.0	9.87	62.3	2.9	41.7	128.6	98.4	9.65	65.5	3.0	44.3	126.7	100.5	9.47	68.2	3.1	45.5		
	23	60	74.4	107.7	5.12	90.2	6.2	38.0	69.7	111.9	4.95	95.0	6.6	41.7	67.7	115.5	4.81	99.1	7.0	43.4		
		80	94.1	105.6	6.78	82.5	4.6	39.0	89.5	109.5	6.59	87.0	4.9	42.4	87.5	112.9	6.43	91.0	5.1	43.9		
		100	113.8	103.5	8.44	74.7	3.6	40.0	109.3	107.2	8.23	79.1	3.8	43.1	107.4	110.3	8.06	82.9	4.0	44.5		
		120	133.5	101.5	10.10	67.0	2.9	41.1	129.1	104.8	9.87	71.1	3.1	43.8	127.2	107.7	9.68	74.7	3.3	45.0		
	30	60	75.0	112.4	5.23	94.6	6.3	37.4	70.2	117.5	5.06	100.2	6.8	41.3	68.1	121.9	4.90	105.1	7.3	43.0		
		80	94.7	110.4	6.92	86.8	4.7	38.4	90.0	115.1	6.73	92.2	5.0	42.0	88.0	119.3	6.56	96.9	5.3	43.5		
		100	114.4	108.3	8.61	78.9	3.7	39.5	109.8	112.8	8.40	84.1	3.9	42.7	107.8	116.7	8.21	88.7	4.2	44.1		
		120	134.2	106.3	10.30	71.1	3.0	40.5	129.6	110.4	10.07	76.1	3.2	43.4	127.6	114.1	9.87	80.4	3.4	44.6		
70	15	60	75.2	113.9	5.10	96.5	6.5	57.1	70.3	118.4	4.94	101.6	7.0	61.2	68.2	122.4	4.80	106.0	7.5	62.9		
		80	94.9	111.8	6.74	88.8	4.9	58.2	90.1	116.1	6.57	93.7	5.2	61.9	88.0	119.8	6.41	97.9	5.5	63.5		
		100	114.6	109.8	8.39	81.1	3.8	59.2	109.9	113.7	8.19	85.8	4.1	62.5	107.8	117.2	8.02	89.8	4.3	64.0		
		120	134.4	107.7	10.03	73.5	3.1	60.2	129.7	111.4	9.82	77.9	3.3	63.2	127.6	114.6	9.63	81.7	3.5	64.6		
	23	60	76.5	124.0	5.24	106.1	6.9	55.8	71.2	129.2	5.06	111.9	7.5	60.3	68.9	133.8	4.91	117.0	8.0	62.2		
		80	96.3	122.0	6.92	98.3	5.2	56.9	91.0	126.9	6.73	103.9	5.5	61.0	88.7	131.2	6.55	108.8	5.9	62.7		
		100	116.0	119.9	8.60	90.6	4.1	57.9	110.8	124.5	8.39	95.9	4.4	61.7	108.6	128.6	8.20	100.6	4.6	63.3		
		120	135.7	117.8	10.28	82.8	3.4	59.0	130.6	122.2	10.05	87.9	3.6	62.4	128.4	126.0	9.85	92.4	3.7	63.8		
	30	60	77.7	132.9	5.37	114.6	7.3	54.7	72.1	138.7	5.17	121.0	7.9	59.5	69.6	143.7	5.00	126.7	8.4	61.6		
		80	97.4	130.8	7.08	106.7	5.4	55.8	91.9	136.3	6.86	112.9	5.8	60.2	89.4	141.1	6.68	118.3	6.2	62.1		
		100	117.2	128.8	8.79	98.8	4.3	56.8	111.7	134.0	8.56	104.8	4.6	60.9	109.2	138.5	8.36	110.0	4.9	62.7		
		120	136.9	126.7	10.50	90.9	3.5	57.9	131.4	131.6	10.25	96.7	3.8	61.6	129.1	135.9	10.03	101.7	4.0	63.2		
90	15	60	76.7	125.6	5.20	107.9	7.1	75.6	71.4	131.4	5.04	114.2	7.6	80.1	69.1	136.5	4.90	119.8	8.2	82.0		
		80	96.5	123.5	6.87	100.1	5.3	76.7	91.2	129.1	6.69	106.2	5.7	80.8	88.9	133.9	6.53	111.6	6.0	82.6		
		100																				
		120																				
	23	60	78.7	140.4	5.36	122.1	7.7	73.7	72.7	146.6	5.17	128.9	8.3	78.8	70.1	152.0	5.01	134.9	8.9	81.0		
		80	98.4	138.3	7.06	114.2	5.7	74.8	92.5	144.2	6.86	120.9	6.2	79.5	90.0	149.4	6.68	126.6	6.6	81.6		
		100	118.2	136.3	8.76	106.4	4.6	75.8	112.3	141.9	8.54	112.8	4.9	80.2	109.8	146.8	8.34	118.3	5.2	82.1		
		120																				
	30	60	80.4	153.3	5.50	134.6	8.2	72.1	73.9	159.9	5.29	141.8	8.9	77.7	71.0	165.6	5.10	148.2	9.5	80.1		
		80	100.2	151.3	7.23	126.6	6.1	73.1	93.7	157.5	7.00	133.6	6.6	78.4	90.9	163.0	6.80	139.8	7.0	80.7		
		100	119.9	149.2	8.97	118.7	4.9	74.2	113.5	155.2	8.72	125.4	5.2	79.1	110.7	160.4	8.50	131.4	5.5	81.2		
		120																				

HT120 - Performance Data

Cooling Capacity

Source		Load Flow - 18 GPM							Load Flow - 28 GPM							Load Flow - 36 GPM						
EST °F	Flow GPM	ELT °F	LLT °F	TC MBTUH	Power kW	HR MBTUH	EER	LST °F	LLT °F	TC MBTUH	Power kW	HR MBTUH	EER	LST °F	LLT °F	TC MBTUH	Power kW	HR MBTUH	EER	LST °F		
30	18	50	35.8	128.0	5.26	145.9	24.3	47.5	41.5	132.6	5.30	150.7	25.0	48.1	43.2	136.3	5.34	154.5	25.5	50.6		
		70	54.0	143.7	5.43	162.2	26.5	49.5	60.4	148.9	5.47	167.5	27.2	50.1	62.4	153.0	5.51	171.8	27.8	52.9		
		90	72.3	159.3	5.60	178.4	28.5	51.4	79.4	165.1	5.64	184.4	29.2	52.1	81.5	169.7	5.68	189.1	29.9	55.2		
		110	90.6	175.0	5.77	194.7	30.3	53.4	98.3	181.3	5.81	201.2	31.2	54.1	100.7	186.4	5.85	206.4	31.9	57.5		
	28	50	35.4	131.3	5.05	148.6	26.0	41.6	41.3	136.1	5.10	153.5	26.7	42.0	43.0	139.9	5.13	157.4	27.3	43.7		
		70	53.6	147.6	5.18	165.2	28.5	42.9	60.2	152.9	5.22	170.7	29.3	43.4	62.1	157.1	5.26	175.1	29.9	45.2		
		90	71.8	163.8	5.31	181.9	30.9	44.2	79.1	169.7	5.35	188.0	31.7	44.7	81.3	174.4	5.38	192.8	32.4	46.8		
		110	90.0	180.0	5.43	198.5	33.1	45.5	98.0	186.5	5.48	205.2	34.1	46.1	100.4	191.7	5.51	210.5	34.8	48.3		
	36	50	35.1	134.0	4.89	150.7	27.4	39.0	41.1	138.8	4.93	155.7	28.2	39.3	42.9	142.7	4.96	159.6	28.8	40.6		
		70	53.3	150.7	4.98	167.7	30.3	40.1	60.0	156.1	5.02	173.2	31.1	40.4	62.0	160.5	5.05	177.7	31.8	41.8		
		90	71.4	167.3	5.07	184.6	33.0	41.1	78.9	173.4	5.11	190.8	33.9	41.4	81.1	178.2	5.15	195.8	34.6	43.1		
		110	89.6	184.0	5.16	201.6	35.7	42.1	97.7	190.7	5.20	208.4	36.6	42.5	100.2	196.0	5.24	213.9	37.4	44.3		
50	18	50	36.7	119.8	6.79	142.9	17.6	67.1	42.0	124.1	6.84	147.4	18.1	67.7	43.6	127.5	6.89	151.0	18.5	70.1		
		70	55.0	135.4	6.95	159.1	19.5	69.1	61.0	140.3	7.01	164.2	20.0	69.7	62.8	144.2	7.06	168.3	20.4	72.4		
		90	73.2	151.1	7.12	175.4	21.2	71.0	79.9	156.5	7.18	181.0	21.8	71.7	82.0	160.9	7.23	185.6	22.3	74.7		
		110	91.5	166.8	7.29	191.6	22.9	73.0	98.9	172.8	7.35	197.9	23.5	73.7	101.1	177.6	7.40	202.8	24.0	77.0		
	28	50	36.2	123.8	6.51	146.0	19.0	61.4	41.8	128.3	6.56	150.7	19.5	61.8	43.4	131.8	6.61	154.4	20.0	63.4		
		70	54.4	140.1	6.64	162.8	21.1	62.7	60.7	145.2	6.70	168.0	21.7	63.2	62.5	149.2	6.74	172.2	22.1	65.0		
		90	72.6	156.4	6.78	179.6	23.1	64.1	79.6	162.1	6.83	185.4	23.7	64.5	81.7	166.6	6.88	190.1	24.2	66.5		
		110	90.8	172.8	6.91	196.3	25.0	65.4	98.5	179.0	6.97	202.8	25.7	65.9	100.8	184.0	7.01	207.9	26.2	68.1		
	36	50	35.9	127.1	6.29	148.5	20.2	58.9	41.5	131.6	6.34	153.3	20.8	59.2	43.2	135.3	6.38	157.1	21.2	60.5		
		70	54.0	143.9	6.40	165.7	22.5	59.9	60.4	149.1	6.45	171.1	23.1	60.3	62.3	153.2	6.49	175.4	23.6	61.7		
		90	72.1	160.7	6.50	182.9	24.7	61.0	79.3	166.5	6.55	188.9	25.4	61.3	81.4	171.2	6.60	193.7	26.0	62.9		
		110	90.3	177.6	6.60	200.1	26.9	62.0	98.2	184.0	6.66	206.7	27.6	62.4	100.5	189.1	6.70	212.0	28.2	64.1		
70	18	50	37.6	111.5	8.31	139.9	13.4	86.8	42.6	115.5	8.38	144.1	13.8	87.3	44.1	118.8	8.44	147.5	14.1	89.7		
		70	55.9	127.2	8.48	156.1	15.0	88.7	61.5	131.8	8.55	160.9	15.4	89.3	63.2	135.4	8.61	164.8	15.7	92.0		
		90	74.1	142.8	8.65	172.3	16.5	90.7	80.5	148.0	8.72	177.7	17.0	91.3	82.4	152.1	8.78	182.1	17.3	94.3		
		110																				
	28	50	37.1	116.3	7.97	143.5	14.6	81.2	42.3	120.5	8.03	147.9	15.0	81.6	43.8	123.8	8.09	151.4	15.3	83.2		
		70	55.3	132.7	8.11	160.4	16.4	82.5	61.2	137.5	8.17	165.4	16.8	82.9	62.9	141.3	8.23	169.4	17.2	84.7		
		90	73.4	149.1	8.25	177.2	18.1	83.9	80.1	154.5	8.32	182.9	18.6	84.3	82.1	158.8	8.37	187.3	19.0	86.3		
		110																				
	36	50	36.7	120.1	7.70	146.4	15.6	78.8	42.0	124.4	7.76	150.9	16.0	79.1	43.6	127.9	7.81	154.5	16.4	80.3		
		70	54.8	137.1	7.81	163.8	17.6	79.8	60.9	142.1	7.87	168.9	18.0	80.1	62.7	146.0	7.93	173.1	18.4	81.5		
		90	72.9	154.1	7.93	181.2	19.4	80.9	79.7	159.7	7.99	187.0	20.0	81.2	81.8	164.1	8.05	191.6	20.4	82.8		
		110																				
90	18	50	38.5	103.3	9.84	136.8	10.5	106.4	43.1	107.0	9.92	140.8	10.8	106.9	44.5	110.0	9.98	144.0	11.0	109.2		
		70	56.8	118.9	10.00	153.0	11.9	108.4	62.1	123.2	10.09	157.6	12.2	108.9	63.7	126.7	10.15	161.3	12.5	111.5		
		90	75.0	134.6	10.17	169.3	13.2	110.3	81.0	139.4	10.25	174.4	13.6	110.9	82.8	143.3	10.32	178.5	13.9	113.8		
		110																				
	28	50	37.9	108.8	9.43	140.9	11.5	101.0	42.8	112.7	9.50	145.1	11.9	101.4	44.2	115.8	9.56	148.5	12.1	102.9		
		70	56.1	125.3	9.57	157.9	13.1	102.4	61.7	129.8	9.65	162.7	13.4	102.7	63.3	133.4	9.71	166.5	13.7	104.5		
		90	74.2	141.8	9.72	174.9	14.6	103.7	80.6	146.9	9.80	180.3	15.0	104.1	82.5	151.0	9.86	184.6	15.3	106.1		
		110																				
	36	50	37.4	113.2	9.10	144.2	12.4	98.7	42.5	117.2	9.17	148.5	12.8	98.9	44.0	120.5	9.23	152.0	13.1	100.1		
		70	55.5	130.3	9.23	161.8	14.1	99.7	61.3	135.0	9.30	166.8	14.5	100.0	63.1	138.8	9.36	170.7	14.8	101.4		
		90	73.6	147.5	9.36	179.4	15.8	100.8	80.2	152.8	9.43	185.0	16.2	101.1	82.1	157.1	9.49	189.5	16.5	102.6		
		110																				
110	18	50	39.4	95.0	11.36	133.8	8.4	126.1	43.7	98.4	11.45	137.5	8.6	126.5	44.9	101.2	11.53	140.5	8.8	128.7		
		70	57.7	110.7	11.53	150.0	9.6	128.0	62.6	114.7	11.62	154.3	9.9	128.5	64.1	117.9	11.70	157.8	10.1	131.0		
		90	76.0	126.3	11.69	166.2	10.8	129.9	81.6	130.9	11.79	171.1	11.1	130.5	83.3	134.5	11.87	175.0	11.3	133.3		
		110																				
	28	50	38.8	101.2	10.88	138.4	9.3	120.8	43.3	104.9	10.97	142.3	9.6	121.1	44.6	107.8	11.04	145.5	9.8	122.7		
		70	56.9	117.8	11.04	155.5	10.7	122.2	62.2	122.1	11.13	160.0	11.0	122.5	63.7	125.5	11.20	163.7	11.2	124.2		
		90	75.1	134.4	11.19	172.6	12.0	123.5	81.0	139.3	11.28	177.8	12.3	123.9	82.8	143.1	11.36	181.9	12.6	125.8		
		110																				
	36	50	38.2	106.2	10.50	142.0	10.1	118.5	42.9	110.0	10.58	146.1	10.4	118.8	44.3	113.1	10.65	149.4	10.6	120.0		
		70	56.3	123.5	10.64	159.9	11.6	119.6	61.8	128.0	10.73	164.6	11.9	119.9	63.4	131.6	10.80	168.4	12.2	121.2		
		90	74.3	140.9	10.79	177.7	13.1	120.7	80.6	146.0	10.87	183.1	13.4	121.0	82.5	150.0	10.94	187.4	13.7	122.5		
		110																				

HT120 - Performance Data

Heating Capacity

Source		Load Flow - 18 GPM							Load Flow - 28 GPM							Load Flow - 36 GPM						
EWT °F	Flow GPM	ELT °F	LLT °F	HC MBTUH	Power kW	HE MBTUH	COP	LST °F	LLT °F	HC MBTUH	Power kW	HE MBTUH	COP	LST °F	LLT °F	HC MBTUH	Power kW	HE MBTUH	COP	LST °F		
20	36	60	70.6	95.2	5.20	77.5	5.4	11.4	66.9	96.9	5.26	79.0	5.4	14.4	65.5	98.3	5.30	80.2	5.4	15.5		
		80	90.3	92.5	7.00	68.6	3.9	12.4	86.7	94.2	7.07	70.1	3.9	15.0	85.3	95.5	7.13	71.2	3.9	16.0		
		100	110.0	89.9	8.80	59.8	3.0	13.4	106.5	91.5	8.89	61.1	3.0	15.6	105.2	92.8	8.97	62.2	3.0	16.5		
		120	129.7	87.2	10.60	51.0	2.4	14.3	126.3	88.8	10.71	52.2	2.4	16.3	125.0	90.0	10.80	53.2	2.4	17.0		
30	28	60	71.0	98.9	5.36	80.6	5.4	21.0	67.3	102.4	5.44	83.8	5.5	24.0	65.8	105.2	5.51	86.4	5.6	25.2		
		80	90.7	96.2	7.16	71.8	3.9	22.0	87.1	99.6	7.26	74.9	4.0	24.7	85.7	102.4	7.34	77.3	4.1	25.7		
		100	110.4	93.6	8.96	63.0	3.1	23.0	106.9	96.9	9.08	65.9	3.1	25.3	105.5	99.6	9.18	68.3	3.2	26.2		
		120	130.1	90.9	10.76	54.2	2.5	24.0	126.7	94.2	10.90	57.0	2.5	25.9	125.4	96.9	11.01	59.3	2.6	26.7		
	36	60	71.2	101.2	5.40	82.8	5.5	20.8	67.6	106.1	5.51	87.3	5.6	23.8	66.1	110.0	5.60	90.9	5.8	25.0		
		80	90.9	98.5	7.20	74.0	4.0	21.8	87.4	103.4	7.33	78.4	4.1	24.4	86.0	107.2	7.43	81.9	4.2	25.5		
		100	110.7	95.9	9.00	65.2	3.1	22.8	107.2	100.6	9.15	69.4	3.2	25.0	105.8	104.5	9.27	72.8	3.3	26.0		
		120	130.4	93.2	10.80	56.4	2.5	23.7	127.0	97.9	10.97	60.5	2.6	25.7	125.7	101.7	11.10	63.8	2.7	26.5		
		50	18	60	72.6	113.4	5.53	94.5	6.0	39.5	68.4	116.9	5.59	97.8	6.1	43.0	66.7	119.7	5.63	100.5	6.2	44.4
				80	92.3	110.7	7.33	85.7	4.4	40.5	88.2	114.2	7.41	88.9	4.5	43.6	86.5	117.0	7.47	91.5	4.6	44.9
				100	112.0	108.0	9.13	76.9	3.5	41.5	108.0	111.5	9.23	80.0	3.5	44.3	106.3	114.2	9.30	82.5	3.6	45.4
				120	131.7	105.4	10.93	68.1	2.8	42.4	127.8	108.7	11.04	71.1	2.9	44.9	126.2	111.4	11.13	73.4	2.9	45.9
28	60		73.3	119.7	5.63	100.5	6.2	38.8	68.9	124.5	5.70	105.1	6.4	42.5	67.1	128.4	5.76	108.7	6.5	44.0		
	80		93.0	117.1	7.43	91.7	4.6	39.8	88.7	121.8	7.52	96.1	4.7	43.1	87.0	125.6	7.60	99.7	4.8	44.5		
	100		112.7	114.4	9.23	82.9	3.6	40.8	108.5	119.1	9.34	87.2	3.7	43.8	106.8	122.8	9.43	90.7	3.8	45.0		
	120		132.4	111.7	11.03	74.1	3.0	41.8	128.3	116.4	11.16	78.3	3.1	44.4	126.7	120.1	11.26	81.6	3.1	45.5		
	36		60	73.9	124.8	5.70	105.4	6.4	38.3	69.3	130.6	5.79	110.9	6.6	42.1	67.5	135.3	5.87	115.2	6.8	43.6	
			80	93.6	122.1	7.50	96.5	4.8	39.3	89.1	127.9	7.61	101.9	4.9	42.7	87.4	132.5	7.70	106.2	5.0	44.1	
			100	113.3	119.5	9.30	87.7	3.8	40.3	108.9	125.2	9.43	93.0	3.9	43.4	107.2	129.7	9.53	97.2	4.0	44.6	
			120	133.0	116.8	11.10	78.9	3.1	41.2	128.7	122.4	11.25	84.1	3.2	44.0	127.1	127.0	11.37	88.2	3.3	45.1	
70	18	60	74.5	130.7	5.77	111.1	6.6	57.7	69.7	136.1	5.82	116.2	6.9	61.7	67.8	140.4	5.87	120.3	7.0	63.3		
		80	94.2	128.1	7.57	102.2	5.0	58.6	89.5	133.4	7.64	107.3	5.1	62.3	87.6	137.6	7.70	111.3	5.2	63.8		
		100	113.9	125.4	9.37	93.4	3.9	59.6	109.3	130.6	9.46	98.4	4.0	63.0	107.5	134.8	9.53	102.3	4.1	64.3		
		120	133.6	122.7	11.17	84.6	3.2	60.6	129.1	127.9	11.28	89.4	3.3	63.6	127.3	132.1	11.37	93.3	3.4	64.8		
	28	60	75.6	140.5	5.90	120.4	7.0	56.6	70.5	146.7	5.96	126.3	7.2	61.0	68.4	151.6	6.01	131.0	7.4	62.7		
		80	95.3	137.9	7.70	111.6	5.3	57.6	90.3	143.9	7.78	117.4	5.4	61.6	88.3	148.8	7.85	122.0	5.6	63.2		
		100	115.0	135.2	9.50	102.8	4.2	58.6	110.1	141.2	9.60	108.5	4.3	62.3	108.1	146.0	9.68	113.0	4.4	63.7		
		120	134.7	132.5	11.30	94.0	3.4	59.6	129.9	138.5	11.42	99.5	3.6	62.9	128.0	143.3	11.51	104.0	3.6	64.2		
		36	60	76.5	148.4	6.00	127.9	7.2	55.8	71.1	155.1	6.07	134.4	7.5	60.4	68.9	160.5	6.13	139.6	7.7	62.2	
			80	96.2	145.7	7.80	119.1	5.5	56.8	90.9	152.4	7.89	125.5	5.7	61.0	88.8	157.8	7.97	130.6	5.8	62.7	
			100	115.9	143.1	9.60	110.3	4.4	57.7	110.7	149.7	9.71	116.6	4.5	61.7	108.6	155.0	9.80	121.6	4.6	63.2	
			120	135.6	140.4	11.40	101.5	3.6	58.7	130.5	147.0	11.53	107.6	3.7	62.3	128.5	152.2	11.63	112.5	3.8	63.7	
90	18	60	76.5	148.1	6.00	127.6	7.2	75.8	71.1	155.3	6.06	134.6	7.5	80.4	68.9	161.0	6.10	140.2	7.7	82.2		
		80	96.2	145.4	7.80	118.8	5.5	76.8	90.9	152.5	7.87	125.7	5.7	81.0	88.8	158.2	7.93	131.2	5.8	82.7		
		100																				
		120																				
	28	60	77.9	161.4	6.17	140.3	7.7	74.4	72.1	168.8	6.22	147.6	8.0	79.5	69.7	174.8	6.27	153.4	8.2	81.5		
		80	97.6	158.7	7.97	131.5	5.8	75.4	91.9	166.1	8.04	138.7	6.1	80.1	89.6	172.0	8.10	144.4	6.2	82.0		
		100	117.3	156.0	9.77	122.7	4.7	76.4	111.7	163.4	9.86	129.7	4.9	80.7	109.4	169.2	9.93	135.4	5.0	82.5		
		120																				
		36	60	79.1	172.0	6.30	150.5	8.0	73.3	72.8	179.7	6.36	158.0	8.3	78.7	70.3	185.8	6.40	164.0	8.5	80.9	
			80	98.8	169.3	8.10	141.7	6.1	74.3	92.6	176.9	8.17	149.1	6.3	79.4	90.2	183.0	8.23	154.9	6.5	81.4	
			100	118.5	166.7	9.90	132.9	4.9	75.2	112.4	174.2	9.99	140.1	5.1	80.0	110.0	180.3	10.07	145.9	5.2	81.9	
			120																			

HT150 - Performance Data

Cooling Capacity

Source		Load Flow - 21 GPM							Load Flow - 32 GPM							Load Flow - 42 GPM						
EST °F	Flow GPM	ELT °F	LLT °F	TC MBTUH	Power kW	HR MBTUH	EER	LST °F	LLT °F	TC MBTUH	Power kW	HR MBTUH	EER	LST °F	LLT °F	TC MBTUH	Power kW	HR MBTUH	EER	LST °F		
30	21	50	33.1	177.0	5.60	196.1	31.6	46.8	39.8	181.2	5.66	200.5	32.0	47.2	42.1	185.0	5.72	204.5	32.3	49.5		
		70	51.7	192.7	5.83	212.6	33.0	48.2	58.9	197.4	5.90	217.6	33.5	48.6	61.4	201.7	5.96	222.1	33.8	51.2		
		90	70.2	208.3	6.07	229.0	34.3	49.6	78.0	213.6	6.14	234.6	34.8	50.1	80.6	218.5	6.21	239.6	35.2	52.8		
		110	88.7	224.0	6.30	245.5	35.6	51.0	97.1	229.9	6.38	251.6	36.0	51.6	99.9	235.2	6.45	257.2	36.5	54.5		
	32	50	33.0	178.0	5.44	196.6	32.7	41.1	39.7	182.5	5.50	201.3	33.2	41.3	42.0	186.6	5.55	205.5	33.6	42.8		
		70	51.5	194.1	5.61	213.2	34.6	42.0	58.8	199.1	5.67	218.4	35.1	42.3	61.3	203.6	5.73	223.2	35.6	43.9		
		90	70.0	210.1	5.77	229.8	36.4	42.9	77.9	215.6	5.84	235.5	36.9	43.2	80.5	220.7	5.90	240.8	37.4	45.1		
		110	88.5	226.1	5.93	246.3	38.1	43.9	96.9	232.2	6.01	252.7	38.6	44.2	99.8	237.7	6.08	258.5	39.1	46.2		
	42	50	33.0	179.0	5.30	197.1	33.8	38.4	39.7	183.7	5.35	202.0	34.3	38.7	41.9	188.0	5.40	206.4	34.8	39.8		
		70	51.4	195.3	5.40	213.8	36.2	39.2	58.7	200.6	5.46	219.2	36.7	39.4	61.2	205.3	5.51	224.1	37.2	40.7		
		90	69.8	211.7	5.50	230.4	38.5	39.9	77.8	217.4	5.57	236.4	39.1	40.1	80.5	222.7	5.63	241.9	39.6	41.5		
		110	88.3	228.0	5.60	247.1	40.7	40.6	96.8	234.3	5.67	253.6	41.3	40.9	99.7	240.0	5.74	259.6	41.8	42.4		
50	21	50	34.7	160.9	7.88	187.8	20.4	72.5	40.7	164.8	7.96	192.0	20.7	73.0	42.8	168.4	8.04	195.8	20.9	76.1		
		70	53.2	176.8	8.11	204.4	21.8	74.5	59.8	181.2	8.19	209.1	22.1	75.1	62.1	185.2	8.28	213.4	22.4	78.5		
		90	71.7	192.6	8.33	221.0	23.1	76.5	78.9	197.6	8.42	226.3	23.5	77.2	81.3	202.1	8.51	231.1	23.7	80.8		
		110	90.1	208.5	8.56	237.7	24.4	78.5	98.0	213.9	8.65	243.5	24.7	79.2	100.6	218.9	8.75	248.7	25.0	83.2		
	32	50	34.6	161.9	7.63	187.9	21.2	64.7	40.7	166.0	7.71	192.3	21.5	65.0	42.7	169.7	7.78	196.3	21.8	67.1		
		70	53.0	178.4	7.80	205.1	22.9	66.0	59.7	183.1	7.89	210.0	23.2	66.4	62.0	187.3	7.97	214.5	23.5	68.7		
		90	71.4	195.0	7.97	222.2	24.5	67.4	78.7	200.2	8.07	227.8	24.8	67.8	81.2	205.0	8.16	232.8	25.1	70.2		
		110	89.8	211.6	8.15	239.4	26.0	68.7	97.8	217.4	8.25	245.5	26.3	69.2	100.5	222.6	8.34	251.1	26.7	71.8		
	42	50	34.5	162.8	7.41	188.0	22.0	61.3	40.6	167.0	7.48	192.6	22.3	61.6	42.7	171.0	7.55	196.7	22.6	63.1		
		70	52.9	180.0	7.53	205.7	23.9	62.3	59.6	184.9	7.61	210.8	24.3	62.6	61.9	189.3	7.69	215.5	24.6	64.4		
		90	71.2	197.2	7.65	223.3	25.8	63.4	78.6	202.7	7.75	229.1	26.2	63.7	81.1	207.6	7.84	234.4	26.5	65.6		
		110	89.6	214.4	7.78	241.0	27.6	64.5	97.6	220.5	7.88	247.4	28.0	64.8	100.3	226.0	7.98	253.2	28.3	66.9		
70	21	50	36.2	144.8	10.16	179.5	14.3	91.5	41.7	148.4	10.26	183.4	14.5	92.0	43.5	151.7	10.36	187.0	14.6	94.9		
		70	54.7	160.9	10.38	196.3	15.5	93.6	60.7	164.9	10.49	200.7	15.7	94.1	62.8	168.7	10.59	204.8	15.9	97.3		
		90	73.2	176.9	10.59	213.0	16.7	95.6	79.8	181.5	10.71	218.0	16.9	96.2	82.0	185.6	10.81	222.5	17.2	99.7		
		110																				
	32	50	36.1	145.7	9.82	179.2	14.8	84.0	41.6	149.4	9.92	183.3	15.1	84.3	43.4	152.9	10.01	187.0	15.3	86.3		
		70	54.5	162.8	10.00	196.9	16.3	85.4	60.6	167.1	10.11	201.6	16.5	85.8	62.7	171.1	10.21	205.9	16.7	87.9		
		90	72.9	180.0	10.18	214.7	17.7	86.8	79.6	184.8	10.30	220.0	17.9	87.2	81.9	189.3	10.41	224.8	18.2	89.5		
		110																				
	42	50	36.0	146.5	9.51	178.9	15.4	80.7	41.5	150.4	9.61	183.2	15.6	81.0	43.4	153.9	9.70	187.0	15.9	82.5		
		70	54.3	164.6	9.66	197.6	17.0	81.9	60.5	169.1	9.77	202.5	17.3	82.1	62.6	173.2	9.87	206.9	17.5	83.8		
		90	72.6	182.7	9.80	216.2	18.6	83.0	79.4	187.9	9.93	221.8	18.9	83.3	81.7	192.6	10.05	226.8	19.2	85.1		
		110																				
90	21	50	37.7	128.7	12.44	171.1	10.3	110.5	42.6	132.0	12.57	174.9	10.5	111.0	44.2	135.1	12.68	178.3	10.7	113.8		
		70	56.2	144.9	12.65	188.1	11.5	112.6	61.6	148.7	12.78	192.3	11.6	113.1	63.5	152.1	12.90	196.1	11.8	116.2		
		90	74.6	161.2	12.86	205.1	12.5	114.6	80.7	165.4	12.99	209.7	12.7	115.2	82.7	169.2	13.12	214.0	12.9	118.5		
		110																				
	32	50	37.7	129.5	12.01	170.5	10.8	103.3	42.5	132.9	12.13	174.3	11.0	103.6	44.2	136.0	12.25	177.8	11.1	105.5		
		70	56.0	147.2	12.20	188.8	12.1	104.8	61.5	151.2	12.33	193.2	12.3	105.1	63.4	154.8	12.46	197.3	12.4	107.2		
		90	74.3	164.9	12.38	207.1	13.3	106.2	80.5	169.4	12.53	212.2	13.5	106.6	82.6	173.6	12.67	216.8	13.7	108.9		
		110																				
	42	50	37.6	130.3	11.62	169.9	11.2	100.2	42.5	133.7	11.74	173.8	11.4	100.4	44.1	136.9	11.85	177.3	11.5	101.8		
		70	55.8	149.3	11.79	189.5	12.7	101.4	61.4	153.4	11.93	194.1	12.9	101.6	63.3	157.2	12.05	198.3	13.0	103.2		
		90	74.0	168.3	11.96	209.1	14.1	102.5	80.3	173.1	12.11	214.4	14.3	102.9	82.4	177.5	12.26	219.3	14.5	104.6		
		110																				
110	21	50	39.3	112.6	14.72	162.8	7.6	129.5	43.5	115.6	14.87	166.4	7.8	130.0	44.9	118.4	15.00	169.6	7.9	132.6		
		70	57.7	129.0	14.92	179.9	8.6	131.6	62.5	132.5	15.07	183.9	8.8	132.1	64.2	135.6	15.21	187.5	8.9	135.0		
		90	76.1	145.5	15.12	197.1	9.6	133.6	81.6	149.3	15.28	201.4	9.8	134.2	83.5	152.8	15.42	205.4	9.9	137.4		
		110																				
	32	50	39.2	113.3	14.20	161.8	8.0	122.7	43.5	116.4	14.34	165.3	8.1	122.9	44.9	119.1	14.48	168.5	8.2	124.7		
		70	57.5	131.6	14.39	180.7	9.1	124.1	62.4	135.2	14.55	184.9	9.3	124.5	64.1	138.5	14.70	188.6	9.4	126.4		
		90	75.7	149.8	14.59	199.6	10.3	125.6	81.3	154.0	14.76	204.4	10.4	126.0	83.2	157.9	14.92	208.8	10.6	128.2		
		110																				
	42	50	39.1	114.0	13.72	160.8	8.3	119.6	43.4	117.0	13.87	164.4	8.4	119.9	44.9	119.8	14.00	167.6	8.6	121.2		
		70	57.2	133.9	13.91	181.4	9.6	120.9	62.3	137.7	14.08	185.7	9.8	121.1	64.0	141.1	14.23	189.7	9.9	122.6		
		90	75.4	153.8	14.11	201.9	10.9	122.1	81.1	158.3	14.30	207.1	11.1	122.4	83.0	162.5	14.47	211.8	11.2	124.1		
		110																				

HT150 - Performance Data

Heating Capacity

Source		Load Flow - 21 GPM							Load Flow - 32 GPM							Load Flow - 42 GPM						
EWT °F	Flow GPM	ELT °F	LLT °F	HC MBTUH	Power kW	HE MBTUH	COP	LST °F	LLT °F	HC MBTUH	Power kW	HE MBTUH	COP	LST °F	LLT °F	HC MBTUH	Power kW	HE MBTUH	COP	LST °F		
20	42	60	70.6	110.8	7.30	85.9	4.4	11.8	67.2	114.8	7.09	90.6	4.7	14.3	65.6	118.4	6.90	94.9	5.0	15.5		
		80	90.1	106.2	9.57	73.6	3.3	13.0	86.9	110.8	9.34	78.9	3.5	15.1	85.5	114.9	9.13	83.8	3.7	16.0		
		100	109.7	101.6	11.83	61.2	2.5	14.2	106.7	106.8	11.59	67.2	2.7	15.8	105.3	111.5	11.37	72.7	2.9	16.5		
		120	129.2	97.0	14.10	48.9	2.0	15.3	126.4	102.8	13.84	55.5	2.2	16.5	125.1	108.0	13.60	61.6	2.3	17.1		
30	32	60	71.5	120.3	6.45	98.3	5.5	20.6	67.7	123.6	6.79	100.5	5.3	23.7	66.0	126.6	7.10	102.4	5.2	25.1		
		80	91.0	116.0	8.50	87.0	4.0	21.7	87.5	119.7	8.93	89.2	3.9	24.4	85.9	123.2	9.33	91.3	3.9	25.7		
		100	110.6	111.6	10.54	75.6	3.1	22.8	107.2	115.8	11.08	78.0	3.1	25.1	105.7	119.7	11.57	80.2	3.0	26.2		
	42	120	130.2	107.2	12.59	64.3	2.5	23.9	127.0	111.9	13.22	66.8	2.5	25.8	125.5	116.2	13.80	69.1	2.5	26.7		
		60	71.7	123.0	7.50	97.4	4.8	20.7	67.9	126.1	7.29	101.3	5.1	23.7	66.1	129.0	7.10	104.8	5.3	25.0		
		80	91.3	118.6	9.77	85.3	3.6	21.9	87.6	122.2	9.54	89.7	3.8	24.4	86.0	125.5	9.33	93.7	3.9	25.5		
		100	110.9	114.3	12.03	73.2	2.8	23.0	107.4	118.4	11.79	78.1	2.9	25.1	105.8	122.1	11.57	82.6	3.1	26.1		
		120	130.5	109.9	14.30	61.1	2.3	24.2	127.2	114.5	14.04	66.6	2.4	25.8	125.6	118.6	13.80	71.5	2.5	26.6		
50	21	60	74.4	151.3	6.43	129.3	6.9	37.7	69.7	155.9	6.90	132.3	6.6	41.7	67.6	160.1	7.33	135.1	6.4	43.6		
		80	94.0	146.9	8.38	118.3	5.1	38.7	89.5	152.0	8.99	121.3	5.0	42.4	87.5	156.6	9.56	124.0	4.8	44.1		
		100	113.6	142.5	10.32	107.3	4.0	39.8	109.3	148.1	11.08	110.3	3.9	43.1	107.3	153.2	11.78	113.0	3.8	44.6		
		120	133.2	138.2	12.27	96.3	3.3	40.8	129.0	144.2	13.17	99.3	3.2	43.8	127.1	149.7	14.00	101.9	3.1	45.1		
	32	60	74.6	153.8	7.22	129.1	6.2	37.7	69.9	158.3	7.29	133.4	6.4	41.7	67.7	162.3	7.35	137.2	6.5	43.5		
		80	94.2	149.4	9.33	117.6	4.7	38.8	89.6	154.4	9.46	122.1	4.8	42.4	87.6	158.9	9.58	126.2	4.9	44.0		
		100	113.8	145.0	11.45	106.0	3.7	39.9	109.4	150.5	11.63	110.8	3.8	43.1	107.4	155.4	11.81	115.1	3.9	44.5		
		120	133.4	140.7	13.56	94.4	3.0	41.0	129.2	146.6	13.81	99.5	3.1	43.8	127.2	151.9	14.03	104.0	3.2	45.0		
	42	60	74.9	156.1	7.93	129.0	5.8	37.7	70.0	160.4	7.64	134.3	6.2	41.6	67.8	164.3	7.37	139.2	6.5	43.4		
		80	94.4	151.7	10.20	116.9	4.4	38.9	89.8	156.5	9.89	122.8	4.6	42.3	87.7	160.9	9.60	128.1	4.9	43.9		
		100	114.0	147.3	12.47	104.8	3.5	40.0	109.5	152.6	12.13	111.2	3.7	43.0	107.5	157.4	11.83	117.0	3.9	44.4		
		120	133.6	143.0	14.73	92.7	2.8	41.2	129.3	148.7	14.38	99.6	3.0	43.8	127.3	153.9	14.07	105.9	3.2	45.0		
70	21	60	77.6	185.1	7.57	159.3	7.2	54.8	71.9	190.9	7.57	165.1	7.4	59.7	69.3	196.2	7.57	170.4	7.6	61.9		
		80	97.2	180.8	9.66	147.8	5.5	55.9	91.7	187.0	9.72	153.9	5.6	60.4	89.2	192.7	9.78	159.4	5.8	62.4		
		100	116.8	176.4	11.74	136.3	4.4	57.0	111.4	183.1	11.87	142.6	4.5	61.1	109.0	189.3	11.99	148.4	4.6	62.9		
		120	136.4	172.0	13.83	124.8	3.6	58.1	131.2	179.2	14.03	131.4	3.7	61.8	128.8	185.8	14.20	137.3	3.8	63.5		
	32	60	77.8	187.2	7.99	160.0	6.9	54.8	72.1	192.9	7.78	166.3	7.3	59.6	69.4	198.0	7.60	172.1	7.6	61.8		
		80	97.4	182.9	10.17	148.2	5.3	55.9	91.8	189.0	9.99	154.9	5.5	60.3	89.3	194.5	9.82	161.0	5.8	62.3		
		100	117.0	178.5	12.35	136.4	4.2	57.0	111.6	185.1	12.19	143.5	4.4	61.0	109.1	191.1	12.05	150.0	4.6	62.9		
		120	136.6	174.1	14.53	124.5	3.5	58.1	131.3	181.2	14.39	132.1	3.7	61.7	128.9	187.6	14.27	138.9	3.9	63.4		
	42	60	78.0	189.1	8.37	160.6	6.6	54.7	72.2	194.7	7.98	167.4	7.1	59.5	69.5	199.7	7.63	173.6	7.7	61.7		
		80	97.6	184.8	10.63	148.5	5.1	55.9	91.9	190.8	10.23	155.8	5.5	60.3	89.3	196.2	9.87	162.5	5.8	62.3		
		100	117.2	180.4	12.90	136.4	4.1	57.0	111.7	186.9	12.48	144.3	4.4	61.0	109.2	192.7	12.10	151.4	4.7	62.8		
		120	136.8	176.0	15.17	124.3	3.4	58.2	131.4	183.0	14.73	132.7	3.6	61.7	129.0	189.3	14.33	140.4	3.9	63.3		
90	21	60	80.9	219.0	8.70	189.3	7.4	72.0	74.1	226.0	8.23	197.9	8.0	77.6	71.1	232.3	7.80	205.7	8.7	80.2		
		80	100.4	214.6	10.93	177.3	5.8	73.1	93.9	222.1	10.44	186.4	6.2	78.3	90.9	228.8	10.00	194.7	6.7	80.7		
		100																				
		120																				
	32	60	81.0	220.7	8.75	190.8	7.4	71.8	74.2	227.5	8.28	199.3	8.1	77.5	71.1	233.7	7.85	206.9	8.7	80.1		
		80	100.6	216.3	11.00	178.8	5.8	73.0	94.0	223.6	10.51	187.7	6.2	78.3	91.0	230.2	10.07	195.9	6.7	80.7		
		100	120.2	211.9	13.25	166.7	4.7	74.1	113.7	219.7	12.75	176.2	5.1	79.0	110.8	226.8	12.29	184.9	5.4	81.2		
		120																				
	42	60	81.2	222.2	8.80	192.2	7.4	71.7	74.3	228.9	8.33	200.5	8.1	77.5	71.2	235.0	7.90	208.0	8.7	80.1		
		80	100.7	217.8	11.07	180.1	5.8	72.9	94.1	225.0	10.58	188.9	6.2	78.2	91.0	231.5	10.13	197.0	6.7	80.6		
		100	120.3	213.5	13.33	168.0	4.7	74.0	113.8	221.1	12.83	177.3	5.1	78.9	110.9	228.1	12.37	185.9	5.4	81.1		
		120																				

HT180 - Performance Data

Cooling Capacity

Source		Load Flow - 24 GPM							Load Flow - 36 GPM							Load Flow - 48 GPM						
EST °F	Flow GPM	ELT °F	LLT °F	TC MBTUH	Power kW	HR MBTUH	EER	LST °F	LLT °F	TC MBTUH	Power kW	HR MBTUH	EER	LST °F	LLT °F	TC MBTUH	Power kW	HR MBTUH	EER	LST °F		
30	24	50	33.6	197.0	6.50	219.2	30.3	46.4	39.9	203.0	6.57	225.4	30.9	46.9	42.2	209.0	6.63	231.6	31.5	49.3		
		70	52.3	212.7	6.73	235.6	31.6	47.7	59.1	219.0	6.81	242.2	32.1	48.2	61.6	225.3	6.89	248.8	32.7	50.7		
		90	71.0	228.3	6.97	252.1	32.8	48.9	78.3	235.0	7.06	259.1	33.3	49.4	80.9	241.7	7.15	266.1	33.8	52.2		
		110	89.7	244.0	7.20	268.6	33.9	50.1	97.5	251.0	7.31	275.9	34.3	50.7	100.3	258.0	7.42	283.3	34.8	53.6		
	36	50	33.5	198.5	6.35	220.2	31.3	41.0	39.8	204.5	6.43	226.4	31.8	41.3	42.1	210.5	6.52	232.7	32.3	42.9		
		70	52.1	214.3	6.57	236.7	32.6	41.8	60.0	199.1	6.66	221.8	29.9	41.1	63.1	183.8	6.75	206.8	27.2	41.5		
		90	70.8	230.2	6.79	253.3	33.9	42.7	80.3	193.6	6.88	217.1	28.1	40.9	84.1	157.0	6.98	180.9	22.5	40.0		
		110	89.5	246.0	7.01	269.9	35.1	43.5	100.6	188.2	7.11	212.4	26.5	40.6	105.1	130.3	7.21	154.9	18.1	38.6		
	48	50	33.3	200.0	6.20	221.2	32.3	38.3	39.7	206.0	6.30	227.5	32.7	38.5	42.1	212.0	6.40	233.8	33.1	39.7		
		70	52.0	216.0	6.40	237.8	33.7	38.9	61.0	179.1	6.50	201.3	27.5	37.5	64.7	142.2	6.60	164.7	21.5	36.9		
		90	70.7	232.0	6.61	254.5	35.1	39.5	82.4	152.2	6.70	175.1	22.7	36.6	87.3	72.4	6.80	95.6	10.7	34.0		
		110	89.3	248.0	6.81	271.2	36.4	40.2	103.7	125.3	6.91	148.9	18.1	35.6	109.9	2.6	7.00	26.5	0.4	31.1		
50	24	50	34.9	180.8	8.86	211.0	20.4	65.8	40.7	186.3	8.96	216.8	20.8	66.3	42.8	191.8	9.05	222.6	21.2	68.6		
		70	53.6	196.7	9.17	227.9	21.5	67.1	59.9	202.5	9.27	234.2	21.8	67.6	62.2	208.4	9.38	240.4	22.2	70.0		
		90	72.3	212.6	9.47	244.9	22.4	68.4	79.1	218.8	9.59	251.6	22.8	68.9	81.6	225.1	9.71	258.2	23.2	71.5		
		110	91.0	228.5	9.78	261.9	23.4	69.6	98.2	235.1	9.91	268.9	23.7	70.2	100.9	241.8	10.05	276.0	24.1	73.0		
	36	50	34.8	182.4	8.62	211.8	21.2	60.6	40.6	188.0	8.73	217.7	21.5	60.9	42.7	193.5	8.84	223.7	21.9	62.4		
		70	53.4	199.4	8.91	229.8	22.4	61.5	60.5	189.1	9.02	219.9	21.0	61.0	63.3	178.8	9.14	210.0	19.6	61.7		
		90	72.0	216.4	9.20	247.8	23.5	62.4	80.5	190.3	9.32	222.1	20.4	61.1	83.8	164.1	9.45	196.3	17.4	60.9		
		110	90.5	233.5	9.48	265.8	24.6	63.3	100.4	191.4	9.62	224.2	19.9	61.2	104.4	149.4	9.75	182.6	15.3	60.1		
	48	50	34.7	184.0	8.38	212.6	22.0	58.0	40.5	189.7	8.50	218.7	22.3	58.2	42.7	193.3	8.63	224.8	22.6	59.4		
		70	53.2	202.1	8.65	231.6	23.4	58.7	61.2	175.7	8.78	205.6	20.0	57.7	64.4	149.2	8.90	179.6	16.8	57.5		
		90	71.6	220.3	8.92	250.7	24.7	59.4	81.9	161.7	9.05	192.6	17.9	57.2	86.1	103.1	9.18	134.4	11.2	55.6		
		110	90.1	238.4	9.19	269.8	25.9	60.1	102.6	147.7	9.32	179.5	15.8	56.7	107.9	57.0	9.45	89.2	6.0	53.7		
70	24	50	36.3	164.5	11.23	202.8	14.6	85.2	41.5	169.5	11.35	208.2	14.9	85.6	43.5	174.5	11.47	213.6	15.2	87.8		
		70	54.9	180.7	11.60	220.3	15.6	86.5	60.7	186.1	11.74	226.1	15.9	87.0	62.8	191.5	11.87	232.0	16.1	89.3		
		90	73.6	196.8	11.98	237.7	16.4	87.8	79.9	202.7	12.12	244.0	16.7	88.3	82.2	208.5	12.27	250.4	17.0	90.9		
		110																				
	36	50	36.1	166.3	10.89	203.4	15.3	80.2	41.4	171.4	11.03	209.0	15.5	80.5	43.4	176.6	11.16	214.7	15.8	81.9		
		70	54.6	184.5	11.25	222.8	16.4	81.1	61.0	179.2	11.39	218.0	15.7	80.9	63.5	173.8	11.54	213.2	15.1	81.8		
		90	73.1	202.7	11.60	242.3	17.5	82.1	80.7	186.9	11.76	227.0	15.9	81.4	83.6	171.1	11.91	211.8	14.4	81.8		
		110																				
	48	50	36.0	168.0	10.55	204.0	15.9	77.6	41.3	173.3	10.71	209.8	16.2	77.9	43.3	178.6	10.86	215.7	16.4	79.0		
		70	54.3	188.3	10.89	225.4	17.3	78.5	61.4	172.2	11.05	209.9	15.6	77.9	64.1	156.2	11.21	194.4	13.9	78.1		
		90	72.6	208.5	11.23	246.9	18.6	79.3	81.4	171.2	11.39	210.0	15.0	77.9	85.0	133.8	11.55	173.2	11.6	77.2		
		110																				
90	24	50	37.6	148.3	13.59	194.6	10.9	104.6	42.4	152.8	13.74	199.6	11.1	105.0	44.1	157.3	13.88	204.6	11.3	107.1		
		70	56.3	164.7	14.04	212.6	11.7	105.9	61.5	169.6	14.20	218.1	11.9	106.4	63.5	174.6	14.36	223.6	12.2	108.6		
		90	74.9	181.1	14.48	230.5	12.5	107.3	80.7	186.5	14.66	236.5	12.7	107.7	82.8	191.9	14.83	242.5	12.9	110.2		
		110																				
	36	50	37.5	150.1	13.16	195.0	11.4	99.8	42.3	154.9	13.32	200.3	11.6	100.0	44.0	159.6	13.49	205.6	11.8	101.4		
		70	55.9	169.5	13.59	215.9	12.5	100.8	61.5	169.2	13.76	216.2	12.3	100.8	63.7	168.9	13.94	216.4	12.1	102.0		
		90	74.3	189.0	14.01	236.8	13.5	101.8	80.8	183.6	14.20	232.0	12.9	101.6	83.3	178.2	14.38	227.2	12.4	102.6		
		110																				
	48	50	37.3	152.0	12.73	195.4	11.9	97.3	42.2	157.0	12.91	201.0	12.2	97.5	43.9	161.9	13.09	206.6	12.4	98.6		
		70	55.5	174.4	13.13	219.2	13.3	98.2	61.6	168.8	13.32	214.3	12.7	98.0	63.9	163.2	13.51	209.3	12.1	98.7		
		90	73.6	196.8	13.54	243.0	14.5	99.1	81.0	180.6	13.74	227.5	13.1	98.5	83.8	164.4	13.93	211.9	11.8	98.8		
		110																				
110	24	50	39.0	132.0	15.96	186.4	8.3	124.0	43.2	136.0	16.13	191.0	8.4	124.3	44.8	140.0	16.30	195.6	8.6	126.3		
		70	57.6	148.7	16.47	204.9	9.0	125.4	62.3	153.2	16.66	210.0	9.2	125.8	64.1	157.7	16.85	215.1	9.4	127.9		
		90	76.2	165.3	16.99	223.3	9.7	126.7	81.5	170.3	17.19	229.0	9.9	127.2	83.4	175.3	17.39	234.7	10.1	129.6		
		110																				
	36	50	38.8	134.0	15.43	186.6	8.7	119.3	43.1	138.3	15.62	191.6	8.9	119.6	44.7	142.6	15.81	196.6	9.0	120.9		
		70	57.1	154.6	15.93	208.9	9.7	120.4	62.0	159.3	16.13	214.3	9.9	120.7	63.9	163.9	16.33	219.6	10.0	122.2		
		90	75.4	175.2	16.42	231.2	10.7	121.6	81.0	180.2	16.64	237.0	10.8	121.8	83.1	185.2	16.85	242.7	11.0	123.5		
		110																				
	48	50	38.7	136.0	14.90	186.8	9.1	117.0	43.0	140.6	15.11	192.2	9.3	117.2	44.6	145.2	15.32	197.5	9.5	118.2		
		70	56.6	160.5	15.38	213.0	10.4	118.0	61.7	165.4	15.60	218.6	10.6	118.2	63.6	170.2	15.82	224.1	10.8	119.3		
		90	74.6	185.1	15.86	239.2	11.7	119.0	80.5	190.1	16.08	245.0	11.8	119.2	82.7	195.1	16.31	250.7	12.0	120.4		
		110																				

HT180 - Performance Data

Heating Capacity

Source		Load Flow - 24 GPM							Load Flow - 36 GPM							Load Flow - 48 GPM						
EWT °F	Flow GPM	ELT °F	LLT °F	HC MBTUH	Power kW	HE MBTUH	COP	LST °F	LLT °F	HC MBTUH	Power kW	HE MBTUH	COP	LST °F	LLT °F	HC MBTUH	Power kW	HE MBTUH	COP	LST °F		
20	48	60	71.8	141.0	9.8	107.6	4.2	11.0	68.1	145.5	9.9	111.7	4.3	13.8	66.3	150.0	10.0	115.9	4.4	15.2		
		80	91.2	134.3	12.9	90.4	3.1	12.5	87.7	138.4	13.0	94.1	3.1	14.8	85.9	142.5	13.1	97.7	3.2	15.9		
		100	110.6	127.7	15.9	73.3	2.3	13.9	107.3	131.4	16.1	76.4	2.4	15.8	105.6	135.1	16.3	79.6	2.4	16.7		
		120	130.1	121.0	19.0	56.2	1.9	15.3	126.9	124.3	19.2	58.8	1.9	16.7	125.3	127.6	19.4	61.4	1.9	17.4		
30	36	60	72.2	146.0	9.2	114.6	4.7	20.4	68.3	150.1	9.3	118.3	4.7	23.4	66.4	154.1	9.4	121.9	4.8	24.9		
		80	91.8	141.0	12.1	99.9	3.4	21.7	88.0	144.9	12.3	103.1	3.5	24.3	86.2	148.8	12.4	106.3	3.5	25.6		
		100	111.3	136.0	14.9	85.1	2.7	22.9	107.8	139.7	15.2	87.9	2.7	25.1	106.0	143.4	15.4	90.7	2.7	26.2		
	48	120	130.9	131.0	17.8	70.3	2.2	24.1	127.5	134.5	18.1	72.7	2.2	26.0	125.8	138.1	18.5	75.1	2.2	26.9		
		60	72.5	150.0	10.1	115.5	4.4	20.4	68.6	154.1	10.3	119.1	4.4	23.4	66.6	158.3	10.4	122.7	4.5	24.9		
		80	92.1	145.0	13.2	100.0	3.2	21.7	88.3	149.1	13.4	103.4	3.3	24.3	86.4	153.2	13.6	106.9	3.3	25.5		
		100	111.7	140.0	16.3	84.4	2.5	23.0	108.0	144.1	16.5	87.7	2.6	25.1	106.2	148.2	16.7	91.0	2.6	26.2		
		120	131.3	135.0	19.4	68.8	2.0	24.3	127.7	139.1	19.7	72.0	2.1	26.0	126.0	143.1	19.9	75.2	2.1	26.9		
50	24	60	74.9	178.7	8.8	148.8	6.0	37.6	70.2	184.0	8.9	153.7	6.1	41.5	67.9	189.3	9.0	158.6	6.2	43.4		
		80	94.4	172.4	11.5	133.1	4.4	38.9	89.9	177.5	11.7	137.5	4.4	42.4	87.6	182.6	11.9	141.9	4.5	44.1		
		100	113.9	166.2	14.3	117.5	3.4	40.2	109.5	171.0	14.6	121.3	3.4	43.3	107.3	175.8	14.8	125.2	3.5	44.8		
		120	133.3	160.0	17.0	101.9	2.8	41.5	129.1	164.5	17.4	105.2	2.8	44.2	127.0	169.0	17.7	108.5	2.8	45.5		
	36	60	75.3	183.8	9.7	150.7	5.5	37.4	70.5	189.3	9.9	155.6	5.6	41.4	68.1	194.8	10.0	160.6	5.7	43.3		
		80	94.8	177.6	12.7	134.1	4.1	38.8	90.2	182.8	12.7	139.5	4.2	42.2	87.8	188.1	12.6	145.0	4.4	44.0		
		100	114.3	171.3	15.8	117.5	3.2	40.2	109.8	176.4	15.5	123.4	3.3	43.1	107.6	181.5	15.3	129.3	3.5	44.6		
		120	133.8	165.1	18.8	101.0	2.6	41.6	129.4	170.0	18.4	107.3	2.7	44.0	127.3	174.9	17.9	113.7	2.9	45.3		
	48	60	75.8	189.0	10.7	152.6	5.2	37.3	70.8	194.6	10.8	157.6	5.3	41.2	68.3	200.2	11.0	162.7	5.3	43.2		
		80	95.2	182.7	14.0	135.1	3.8	38.7	90.5	188.2	13.7	141.6	4.0	42.1	88.1	193.7	13.4	148.1	4.2	43.8		
		100	114.7	176.4	17.2	117.6	3.0	40.2	110.1	181.8	16.5	125.5	3.2	43.0	107.8	187.2	15.8	133.5	3.5	44.4		
		120	134.2	170.1	20.5	100.1	2.4	41.7	129.7	175.4	19.3	109.5	2.7	43.9	127.5	180.7	18.1	118.9	2.9	45.0		
	70	24	60	77.9	215.3	9.2	183.8	6.8	54.7	72.3	222.0	9.4	189.9	6.9	59.4	69.5	228.7	9.6	196.1	7.0	61.8	
			80	97.3	207.9	12.1	166.5	5.0	56.1	91.9	214.3	12.3	172.3	5.1	60.4	89.2	220.8	12.5	178.0	5.2	62.6	
			100	116.7	200.4	15.0	149.2	3.9	57.6	111.5	206.7	15.3	154.6	4.0	61.4	108.9	212.9	15.5	160.0	4.0	63.3	
			120	136.1	193.0	17.9	131.9	3.2	59.0	131.1	199.0	18.2	136.9	3.2	62.4	128.5	205.0	18.5	142.0	3.3	64.1	
36		60	78.5	221.7	10.2	186.7	6.3	54.4	72.7	228.5	10.4	193.0	6.4	59.3	69.8	235.4	10.6	199.3	6.5	61.7		
		80	97.8	214.1	13.4	168.4	4.7	56.0	92.3	220.8	13.1	176.0	4.9	60.2	89.5	227.5	12.8	183.6	5.2	62.3		
		100	117.2	206.6	16.6	150.0	3.6	57.5	111.8	213.1	15.9	159.0	3.9	61.2	109.1	219.6	15.1	167.9	4.3	63.0		
		120	136.6	199.1	19.8	131.6	3.0	59.0	131.4	205.4	18.6	141.9	3.2	62.1	128.8	211.7	17.4	152.3	3.6	63.7		
48		60	79.0	228.0	11.2	189.6	5.9	54.2	73.1	235.0	11.4	196.1	6.0	59.1	70.1	242.1	11.6	202.6	6.1	61.6		
		80	98.4	220.4	14.7	170.2	4.4	55.8	92.6	227.3	13.9	179.7	4.8	60.0	89.8	234.2	13.2	189.2	5.2	62.1		
		100	117.7	212.8	18.2	150.8	3.4	57.4	112.2	219.5	16.5	163.3	3.9	60.9	109.4	226.3	14.8	175.9	4.5	62.7		
		120	137.1	205.2	21.6	131.4	2.8	59.1	131.8	211.8	19.0	147.0	3.3	61.8	129.1	218.4	16.4	162.5	3.9	63.2		
90	24	60	81.0	252.0	9.7	218.9	7.6	71.8	74.4	260.0	9.9	226.2	7.7	77.4	71.2	268.0	10.1	233.5	7.8	80.3		
		80	100.3	243.3	12.7	199.9	5.6	73.3	94.0	251.2	12.9	207.0	5.7	78.5	90.8	259.0	13.1	214.2	5.8	81.1		
		100																				
		120																				
	36	60	81.6	259.5	10.8	222.8	7.1	71.4	74.9	267.8	10.9	230.4	7.2	77.2	71.5	276.0	11.1	238.0	7.3	80.1		
		80	100.9	250.7	14.1	202.6	5.2	73.1	94.4	258.8	13.6	212.5	5.6	78.2	91.1	266.8	13.1	222.3	6.0	80.7		
		100	120.2	241.9	17.4	182.4	4.1	74.8	113.9	249.8	16.2	194.5	4.5	79.2	110.7	257.7	15.0	206.6	5.0	81.4		
		120																				
	48	60	82.3	267.0	11.8	226.7	6.6	71.1	75.3	275.5	12.0	234.6	6.7	77.0	71.8	284.0	12.2	242.5	6.8	79.9		
		80	101.5	258.1	15.5	205.3	4.9	72.9	94.8	266.4	14.2	217.9	5.5	77.9	91.4	274.7	13.0	230.4	6.2	80.4		
		100	120.8	249.2	19.1	184.0	3.8	74.7	114.3	257.3	16.4	201.2	4.6	78.8	111.1	265.3	13.8	218.3	5.6	80.9		
		120																				

Engineering Guide Specifications

General

The liquid source water-to-water heat pump shall be a single packaged reverse-cycle heating/cooling unit. The unit shall be listed by a nationally recognized safety-testing laboratory or agency, such as ETL Testing Laboratory, Underwriters Laboratory (UL), or Canadian Standards Association (CSA). The unit shall be rated in accordance with Air Conditioning, Heating, and Refrigeration Institute/International Standards Organization (AHRI/ISO) and Canadian Standards Association (CSA-US). The liquid source water-to-water heat pump unit shall be designed to operate with source liquid temperatures between 30°F [1.1°C] and 110°F [43.3°C] in cooling, and between 20°F [-6.7°C] and 90°F [32.2°C] in heating.

Casing and Cabinet

The cabinet shall be fabricated from heavy-gauge galvanized steel and finished with corrosion-resistant powder coating. This corrosion protection system shall meet the stringent 1,000 hour salt spray test per ASTM B117. The interior shall be insulated with 1/2" thick, multi-density, coated glass fiber for noise suppression.

The control box shall have separate holes and knockouts for entrance of line voltage and low voltage control wiring. All factory-installed wiring passing through factory knockouts and openings shall be protected from sheet metal edges at openings by plastic ferrules. The control box shall be field switchable from front to back for improved application flexibility with quick attach low voltage harnesses. The control box is shipped standard on the opposite end of the water connections.

Refrigerant Circuit

All units shall contain two (2) sealed refrigerant circuits, each containing a hermetic motor scroll compressor, bidirectional thermal expansion valve assemblies, reversing valve, braze plate heat exchangers, factory installed high and low pressure safety switches, freeze detection, service ports, and liquid line filter dryers. Compressors shall be scroll types designed for heat pump duty with internal isolation and mounted on rubber vibration isolators. Compressor motors shall have internal overload protection. A high density sound attenuating blanket shall be factory installed around the compressor to reduce sound. The water to refrigerant heat exchangers shall be interlaced copper brazed, 316 stainless plate steel, capable of withstanding 650 psig [4489 kPa] working pressure on the refrigerant side and 450 psig [3108 kPa] on the water side. The thermal expansion valve assembly shall provide proper superheat over the liquid temperature range with minimal "hunting." The assembly shall operate bidirectionally without the use of check valves. Externally mounted pressure controlled water regulating flow valves are not acceptable.

Piping and Connections

Supply and return water connections shall be 2 in. [50.8 mm] FPT copper fittings fixed to the cabinet by use of a captive fitting, which eliminates the need for backup pipe wrenches.

Optional Back/Top Mount Water Connections - shall be factory installed to the back corner post or top panel by use of a captive fitting, which eliminates the need for backup pipe wrenches.



WARNING: Warranty is void if strainers are not used on the entering side of the load and source.

Electrical

Controls and safety devices will be factory wired and mounted within the unit. Controls shall include 24 Volt activated compressor contactors, 24VAC-75VA transformer with built in circuit breaker, reversing valve coils, and anti short-cycle protection. A terminal block with screw in terminals will be provided for field control wiring. To prevent short cycling when the safety controls are activated, the reset relay shall provide a lockout circuit that requires resetting of low voltage supply or main circuit breaker. A lockout signal shall be provided to the display to indicate a lockout situation. Units shall be name-plated for use with time delay fuses or HACR circuit breakers. Unit controls shall be 24 Volt and provide heating or cooling as required by the remote thermostat/sensor.

Optional GeoStart™ (Compressor Soft Starter) - shall be factory installed for use in applications that require low starting amps, reduced compressor start-up noise, off-grid, and improved start-up behavior. GeoStart shall reduce normal starting current by 60% on 208/60/1 units.

Microprocessor Control

The unit shall be controlled using an FX10 microprocessor which sequences all functions and modes of operations. The control shall interface with a (Y,B) thermostat, mechanical or electronic. The control shall have the ability to communicate with N2 Open, BacNet, or LonWorks protocols with optional communication card. The control system shall have the following features:

1. Anti-short cycle time delay on compressor operation, time delay shall be a minimum of 3 minutes
2. Random start on power up mode
3. Low voltage protection
4. High voltage protection
5. Unit shutdown on high or low refrigerant pressures
6. Unit shutdown for low water temperature
7. Source and Load heat exchanger low water temperature cutout selectable for water or anti-freeze
8. Automatic intelligent reset (Unit will automatically reset 5 minutes after trip if the fault has cleared. Should a fault reoccur 3 times sequentially then permanent lockout will occur.)

Engineering Guide Specifications cont.

9. A 4 x 20 digit backlit LCD to display the following:
 - a. Entering and leaving water temperatures
 - b. High pressure, low pressure, low voltage, high voltage, low water temperature cutout, and control status
10. The low pressure shall not be monitored for the first 120 seconds after a compressor start command to prevent nuisance safety trips.
11. Remote fault indication on the thermostat
12. An accessory relay output tied to each compressor selectable for normally open or normally closed

Accessories

Flow Proving Switch

Part Number - FPS300

A flow proving switch shall be available utilizing high reliability flow sensing technology.

Strainer Connection Kit

Part Number - CKNDW1

A strainer connection kit shall be available and includes a 2 in. [50.8 mm] Y-strainer with self-aligning screen and 1 in. [25.4 mm] blow-off port to reduce debris that will enter the heat exchanger. Strainers should be made of a brass body with a 316 stainless steel screen. Connection kit shall also include a 2 in. [50.8 mm] wrought copper tee with integral pressure/temperature port.

Strainer Hose Kit Set

Part Number - HHK162S

A strainer hose kit set shall be available and includes a 2 in. strainer loaded with 20-40 mesh screen and blow down valve, 2 in. stainless steel braid hose, 2 in. ball valve with integral pressure/temperature port and a JIC swivel fitting on the supply and 2 in. stainless steel braid hose and 2 in. ball valve with integral pressure/temperature port and a JIC swivel fitting on the return hose. The hose kit assembly shall be pressure rated at 300 psi working pressure.

NOTE: A strainer kit is required on both sides to reduce heat exchanger fouling and potential damage.

Notes

GEOSMART ENERGY



290 Pinebush Road, Cambridge, Ontario N1T 1Z6 | o: 1.866.310.6690 | f: 1.866.533.3889

GEOSMARTENERGY.COM

Product: **Premium H Series – HT**
Type: Hydronic Heat Pump
Size: 8-15 Ton

Document Type: Specification Catalogue
Ref. Number: SC1007WH2
Revision Date: 10/09
Revision Number: 1
Document Name: TEC-SPC-HT-1009v1